



CASTLE PUMPS LTD

Your process delivered.



Datasheet

Power saving
due to less friction
from the rollers

Reversible operation allows flexible
installation, tank to tank transfer and
fluid recovery from dispensing hose

Suction lift and self-priming ability
enables pump to dry run without damage
and low moisture content fluid handling

**Simple, low cost
maintenance** due
to the hose being
the only wearing
part; and with the
absence of valves
and mechanical
seals cleaning and
replacing is easy



Motor and gear
reducer shaft aren't
needed to support
internal axial loads,
due to **heavy duty
internal ball bearing
box** - increasing
strength and life span

Wrapped inner and
outer hose,
reinforced with high
density pressed
Nylon for **longer
lifespan.**

Proportional motor
speed to flow - ideal
for **accurate dosing
without slippage** -
due to rollers clamping
hose in opposing
locations

Handles solids and shear sensitive fluids
due to **gentle pumping motion and low
rpm** preventing change to fluid structure

Leak free connection due to double conical
hose clamp, making it one of the safest systems
available and easily adaptable to any connections

Series **FMP** Self Priming Peristaltic Pump

FMP Peristaltic Pump



Drive Options

- Geared Motor
- Motor variator with gear reducer
- Geared motor with integrated inverter

Performance Tables

	FMP-30	FMP-40	FMP-50	FMP-60	FMP-70
Max Flow rate	0.433 L/rev	0.75 L/rev	1.34 L/rev	3.161 L/rev	6.7 L/rev
Connections	1 ¼"	1 ½"	DN40	DN50	DN65
Max Pressure	8 bar	8 bar	8 bar	8 bar	8 bar
Pressing Tube System	Rollers	Rollers	Rollers	Rollers	Rollers
Available Tubes	NR, NBR, EPDM, HYPALON NR-A, NBR-A	NR, NBR, EPDM, HYPALON, NR-A, NBR-A	NR, NBR, EPDM, HYPALON, NR-A, NBR-A	NR, NBR, EPDM, HYPALON, NR-A, NBR-A	NR, NBR, EPDM, HYPALON, NR-A, NBR-A
Tubes available in thermoplastic	NORPRENE	NORPRENE			

Performance Curve

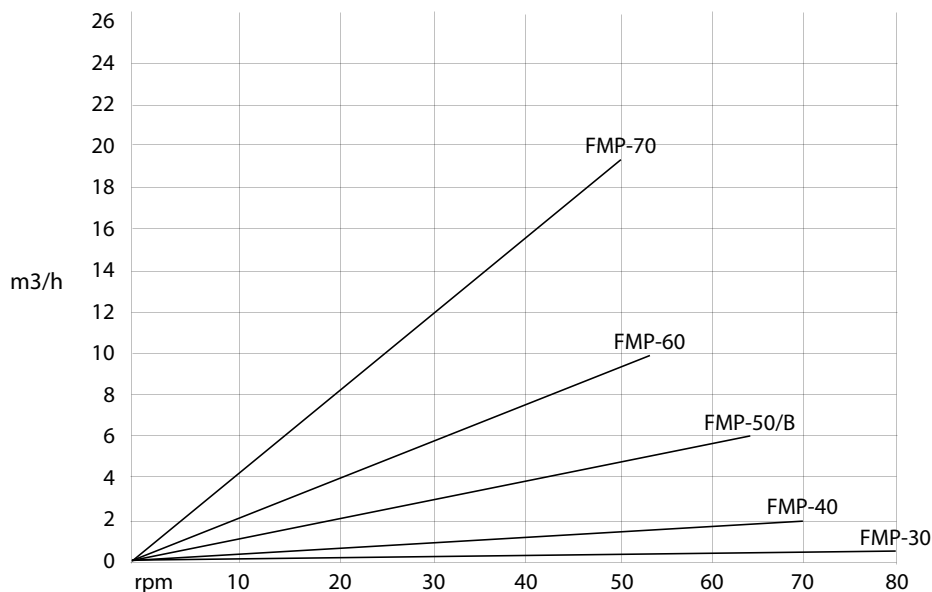

Typical Applications

Ideal for highly viscous and solid laden mediums. The wide variety of materials that the inner tube is available in and the seal-less design, makes them also suitable for chemicals and aggressive fluids.

- Food and drink manufacturing
- Oil sludge, clay, lime slurries, cement
- Paint, ink, glue, pigment and dye
- Sewage and waste water
- Chemical and corrosive fluid dosing
- Pulp and paper slurries



Double Conical Ring Design



Design Benefits

- Patented double conical hose clamp design ensures leak free connection, making it one of the safest systems available and easy to adapt to any connections on the market.
- Heavy duty, internal ball bearing box that means that the motor and gear reducer shaft do not have to support all the internal axial loads, adding strength and increasing life span.
- Wrapped inner and outer hose, reinforced with high density pressed Nylon for longer life.
- Simple and low cost maintenance compared to other pump technologies due to the hose being the only wearing part which is easy to clean and replace, thanks to the absence of valves that can clog and mechanical seals that can wear.
- Good suction lift and self-priming capabilities, meaning that the pump can dry run without damage and handle fluids with low moisture content.
- Reversible operation allowing the flexibility of installations, tank to tank transfer and the recovery of fluid from the dispensing hoses if required at the end of transfer.
- Motor speed is proportional to flow, makes it ideal for dosing applications. Dosing is accurate without slippage due to rollers/shoes clamping hose in opposing locations.
- Ability to handle solids as well as shear sensitive fluids thanks to its gentle pumping motion and low rpm preventing change to a fluid's structure.

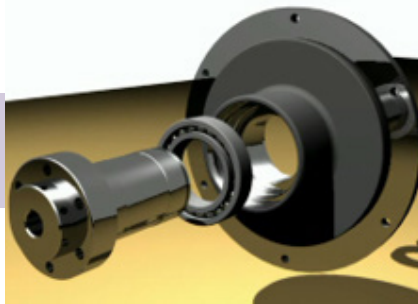

Heavy Duty Ball Bearing Box

Roller Operation

Fluid is moved along inner tube by rollers compressing against it as they rotate. As less friction is generated by the rollers in comparison to shoe designs, such models have:

- Lower power consumption, with up 30% energy savings compared to shoe
- Low starting torque, giving a smoother operation and easier to adjust speed
- Easier hose maintenance as it doesn't require lubrication





Trolley Mounted with Control Panel



Accessories Available

Inline Pulsation Dampener –

Ensures a continuous, smooth flow for the accurate use of flow meters and pressure switches. By eliminating vibrations and hammering, operation is relatively quiet and working life is increased.

Hose Leakage Sensor –

Should the only wearing part of the pump (the hose) fail, the sensor can shut off the pump or activate an alarm to allow the situation to be addressed quickly. This makes the pump ideal for remote installations or where hazardous fluids are handled.

Vacuum Assisted Priming –

Improves the pump's self-priming capability in installations involving particularly viscous fluids or difficult suction conditions.

Halar (ECTFE) Coating –

Improves the corrosion resistance of the pump in chemical or other hazardous applications.

PP/PDV Connections –

As standard, connections are Stainless Steel, but for chemical applications they can be supplied in alternative materials.

Integrated Control Panel –

Can be configured as per the user requirements with features such as on/off, speed control, reversing switch, flow and pressure display, leakage warning.

Trolley or Base Plate –

For the flexibility of installation and enhanced mobility where required.

Inverter –

Pump speed can be slowed down to the required flow, extending the life span of the motor by not making it unnecessarily work to full capacity, and reducing wasted energy costs.

Feed Screw and Hopper –

For the pumping of highly viscous fluids that don't flow with ease and are prone to bridging.



Vacuum Priming Device

Hopper Feed

