



DEBEM s.r.l. - Via Del Bosco, 41 - Busto Arsizio (VA) ITALY  
Tel. (+39) 0331/074034 - fax (+39) 0331/074036 - info@debem.it - www.debem.com

**INDUSTRIAL PUMPS**

CHEMICAL / PAINTING / PRINTING / WATER TREATMENT / GALVANIC / TEXTILE / CERAMIC / AUTOMOTIVE / MECHANICAL / OIL & GAS

info@debem.it - www.debem.com



## IDENTIFICATION AND NOMENCLATURE OF PARTS

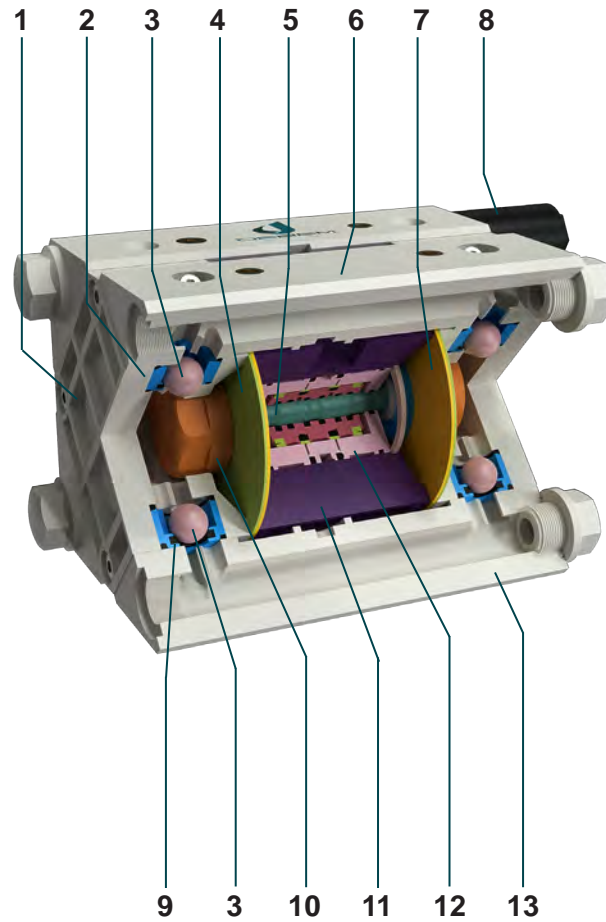

POS.	NOMENCLATURE	POS.	NOMENCLATURE
1	PUMP CASING	8	AIR EXHAUST SILENCER
2	BALL SEAT DELIVERY VALVES	9	SUCTION BALL VALVE SEAT
3	BALL	10	CAP
4	OUTER DIAPHRAGM (product side)	11	DISTRIBUTOR CENTRAL BODY
5	SHAFT	12	PNEUMATIC EXCHANGER
6	DELIVERY MANIFOLD	13	SUCTION MANIFOLD
7	INNER DIAPHRAGM (air side)		

All rights of total or partial reproduction, translation and adaptation by any means are reserved in all countries.  
Layout and creation of contents: Infografica sas

## TABLE OF CONTENTS

<b>CHAPTER 1</b>	<b>GUIDANCE DOCUMENTS</b>	<b>4 - 12</b>
1.1	DECLARATION OF CONFORMITY	5
1.2	LIST OF RESIDUAL RISKS	6
1.3	INTRODUCTION TO THE MANUAL	7 - 10
1.4	DELIVERY NOTE	11
1.5	GENERAL NOTES ON DELIVERY	11
1.6	WARRANTY	12
<b>CHAPTER 2</b>	<b>INTRODUCTORY INFORMATION</b>	<b>13 - 21</b>
2.1	PUMP IDENTIFICATION	14
2.2	PUMP CONFIGURATION CODE	15
2.3	ATEX MARKING AND DEFINITION	16 - 17
2.4	PUMP DESCRIPTION	18
2.5	INTENDED USE AND IMPROPER USES	18 - 19
2.6	TECHNICAL FEATURES	20 - 21
<b>CHAPTER 3</b>	<b>WARNINGS AND REQUIREMENTS</b>	<b>22 - 26</b>
3.1	SAFETY RULES	23 - 26
<b>CHAPTER 4</b>	<b>TRANSPORT AND INSTALLATION</b>	<b>27 - 36</b>
4.1	STORAGE AND PRESERVATION	28
4.2	TRANSPORT AND HANDLING	29
4.3	POSITIONING AND INSTALLATION	30 - 33
4.4	PNEUMATIC CONNECTION	34 - 36
4.5	CHECKS BEFORE COMMISSIONING	36
<b>CHAPTER 5</b>	<b>COMMISSIONING AND SHUTDOWN</b>	<b>37 - 41</b>
5.1	COMMISSIONING AND OPERATION	38 - 39
5.2	NORMAL SHUTDOWN OF THE PUMP	40
5.3	EMERGENCY STOP OF THE PUMP	41
<b>CHAPTER 6</b>	<b>ROUTINE MAINTENANCE</b>	<b>42 - 55</b>
6.1	SCHEDULED MAINTENANCE TABLE	43
6.2	EXTERNAL CLEANING AND TIGHTNESS CHECK	44 - 45
6.3	TIGHTNESS CHECK	46 - 47
6.4	PRODUCT CIRCUIT MAINTENANCE	48 - 52
6.5	AIR CIRCUIT MAINTENANCE	53 - 55
<b>CHAPTER 7</b>	<b>TROUBLESHOOTING</b>	<b>56 - 57</b>
<b>CHAPTER 8</b>	<b>DECOMMISSIONING AND DISPOSAL</b>	<b>58 - 62</b>
8.1	DECOMMISSIONING AND WASHING FORM	59 - 60
8.2	DISPOSAL	61 - 62
<b>CHAPTER 9</b>	<b>SPARE PARTS</b>	<b>63 - 69</b>
9.1	MIDGETBOX SPARE PARTS	64 - 65
9.2	CUBIC 15 SPARE PARTS	66 - 67
	NOTES	68 - 71

## CHAPTER 1

This chapter includes the Declaration of Incorporation, the List of Residual Risks and information on the structure of the Original Instructions so that Operators and Technicians can properly consult the manual itself.

THIS PART INCLUDES THE FOLLOWING TITLES		PAGE
<b>1.1</b>	<b>DECLARATION OF CONFORMITY</b>	<b>5</b>
<b>1.2</b>	<b>LIST OF RESIDUAL RISKS</b>	<b>6</b>
<b>1.3</b>	<b>INTRODUCTION TO THE MANUAL</b>	<b>7 - 10</b>
<b>1.4</b>	<b>DELIVERY NOTE</b>	<b>11</b>
<b>1.5</b>	<b>GENERAL NOTES ON DELIVERY</b>	<b>11</b>
<b>1.6</b>	<b>WARRANTY</b>	<b>12</b>

Below is a detailed description of each topic mentioned.

## 1.1 DICHIARAZIONE DI CONFORMITÀ - DECLARATION OF CONFORMITY



## CUBIC STANDARD

DICHIARAZIONE (CE - UE) DI CONFORMITÀ  
DECLARATION (CE - UE) OF CONFORMITY

FABBRICATO DA: MANUFACTURED BY

DEBEM SRL - Via del bosco 41 - 21052 Busto Arsizio (VA) - ITALIA

LA PRESENTE DICHIARAZIONE DI CONFORMITÀ È RILASCIATA SOTTO LA RESPONSABILITÀ ESCLUSIVA DEL FABBRICANTE.  
This declaration of conformity is issued under the sole responsibility of the manufacturer.

TIPO: TYPE

POMPA PNEUMATICA A MEMBRANA / AIR OPERATED DIAPHRAGM PUMP

MARCATURA ATEX: MARKING ATEX

II 3G Ex h IIB T4 Gc

II 3D Ex h IIB T135°C Dc X

MODELLO: MODEL  
MODELLON° DEPOSITO: DEPOSIT NUMBER  
8000310728CODICE: CODE  
CODICEMATRICOLA: SERIAL NUMBER  
MATRICOLA

L'oggetto della dichiarazione di cui sopra è conforme alle pertinenti normative di armonizzazione dell'Unione:  
The object of the declaration described above is in conformity with the relevant Union harmonisation legislation:

2006/42/CE : Direttiva Macchine / Machinery Directive

2014/34/UE: Direttiva ATEX, concernente l'armonizzazione delle legislazioni degli Stati membri relative agli apparecchi e sistemi di protezione destinati a essere utilizzati in atmosfera potenzialmente esplosiva (rifusione)

2014/34/UE: ATEX Directive, on the harmonisation of the laws of the Member States relating to equipment and protective systems intended for use in potentially explosive atmospheres (recast)

UNI EN ISO 12100:2010 - Sicurezza del macchinario - Principi generali di progettazione - Valutazione del rischio e riduzione del rischio.

UNI EN ISO 12100:2010 - Safety of machinery - General principles for design - Risk assessment and risk reduction.

UNI EN 809:2009 - Pompe e gruppi di pompaggio per liquidi - Requisiti generali di sicurezza.

UNI EN 809:2009 - Pumps and pump units for liquids - Common safety requirements.

EN ISO 80079-36:2016 - Atmosfere esplosive - Parte 36: Apparecchi non elettrici destinati ad essere utilizzati in atmosfere potenzialmente esplosive. Metodo e requisiti di base

EN ISO 80079-36:2016 - Explosive atmospheres - Part 36: Non-electrical equipments to be used in potentially explosive environments. Method and basic requirements.

EN ISO 80079-37:2016 - Atmosfere esplosive - Parte 37: Apparecchi non elettrici per atmosfere potenzialmente esplosive. Tipo di protezione non elettrica per sicurezza costruttiva "c" con controllo della sorgente di accensione "b", per immersione in liquido "k".

EN ISO 80079-37:2016 - Explosive atmospheres - Part 37: Non-electrical equipment for explosive atmospheres. Non-electrical type of protection constructional safety "c" control of ignition sources "b", liquid immersion "k".

ESTENSIONI: la presente dichiarazione si estende anche ai modelli MIDGETBOX e ai relativi modelli SCUBIC e SMIDGET.

EXTENSIONS: this declaration is also valid for the following versions MIDGETBOX and related SCUBIC and SMIDGET models.

**⚠ ATTENZIONE:** data l'innumerabile varietà di prodotti e composizioni chimiche, l'utilizzatore è ritenuto il maggior conoscitore delle reazioni e compatibilità con i materiali costruttivi della pompa. Pertanto, prima dell'impiego, eseguire con perizia tutte le verifiche e prove necessarie al fine di evitare situazioni pericolose anche se remote che non possono essere conosciute ed imputabili al costruttore. Per ogni controversia il Foro Competente è quello di Busto Arsizio.

**⚠ WARNING:** since there exists an endless variety of products and chemical compositions, the user is presumed to have the best knowledge of their reaction and compatibility with the materials used to build the pump. Therefore, before using the pump, all the necessary checks and tests must be performed with great care to avoid even the slightest risk, an event that the manufacturer cannot foresee and of which he cannot be held responsible. Any controversy lies within competence of the Court of Busto Arsizio.

PERSONA AUTORIZZATA A CUSTODIRE IL FASCICOLO: PERSON AUTHORISED TO KEEP THE FILE

MARCO DE BERNARDI - SOCIO AMMINISTRATORE

LUOGO PRESSO CUI È CUSTODITO IL FASCICOLO: THE FILE IS KEPT IN  
VIA DEL BOSCO, 41 - 21052 BUSTO ARSIZIO (VA) - ITALIA

APPROVATO DA: APPROVED BY

MARCO DE BERNARDI - SOCIO AMMINISTRATORE

LUOGO: BUSTO ARSIZIO - DATA: DATASPED



## 1.2 LIST OF RESIDUAL RISKS



After careful analysis and evaluation of the hazards involved in the operating phases of the CUBIC series of air-operated pumps, the necessary measures have been taken to eliminate or reduce the related risks. The residual risks were reported and dealt with in the Installation, Use, and Maintenance Manual (Original Instructions) provided with the pump, so that they can be further reduced or eliminated through the design of the machines in which they will be installed and the integration of safety measures:

### HANDLING AND POSITIONING - CONSULT PROCEDURES IN THE ORIGINAL INSTRUCTIONS

- Impact and crushing hazard

### INSTALLATION - CONSULT PROCEDURES IN THE ORIGINAL INSTRUCTIONS

- Hazards related to toxic and/or corrosive liquids to be pumped;
- Danger of chemical incompatibility with the fluids to be pumped;
- Danger of product leakage with dangerous fluids; (provide flow and collection containment protections);
- Danger of chemical reaction with fluids reacting to tap water for testing; (open and dry the internal parts of the pump before installing it);
- Crushing hazard.

### OPERATION - CONSULT PROCEDURES IN THE ORIGINAL INSTRUCTIONS

- Hazards related to toxic and/or corrosive liquids to be pumped;
- Danger of chemical incompatibility with the fluids to be pumped;
- Danger of stress corrosion cracking (combined action of corrosion and/or incorrect application of a load) combined with high temperatures;
- Fire hazard due to the deposit of flammable dust or use with temperatures higher than those shown on the product Identification Plate.

### CLEANING AND MAINTENANCE - CONSULT PROCEDURES IN THE ORIGINAL INSTRUCTIONS

- Hazards related to toxic and/or corrosive liquids to be pumped;
- Danger of projection of pump parts during disassembly due to residual internal pressures (anomalous) in the pneumatic circuit of the pump;
- Danger of rupture of diaphragms due to lack of Scheduled Maintenance.

The persons in charge of designing the machine/system in which the CUBIC series air-operated pumps will be installed must consider the residual risk indicated in each operational phase and must take the necessary safety integration measures provided by the applicable directives before commissioning. **It is forbidden to commission the pump before the machine in which it is to be incorporated has been declared compliant with Directive 2006/42/EC and any further applicable specific Regulations and/or Directives.**

Whoever works in these areas and deals with these operational phases must be trained and aware that there may still be "residual risks" (related to the type of fluid used and the chemical compatibility) that it was not possible to eliminate.

The persons in charge of these operations must always have at their disposal (consult and understand) all the information contained in the Manufacturer's Manual (Original Instructions or Translation of Original Instructions) and must obtain the necessary Personal Protective Equipment (PPE) provided before intervening.

The Customer, the Installation and Maintenance Technicians, and the Qualified Operators are responsible for arranging all the necessary measures so that access near the pump is reserved and limited to trained and qualified personnel and for providing adequate information and reports of any residual risk on the machine/system in which it will be installed, in compliance with current safety laws.

Since an endless variety of products and chemical compositions of the fluids exists, the user is presumed to have the best knowledge of their compatibility and chemical reaction with the pump's construction materials. **The purchaser is strictly responsible for selecting the construction materials compatible with the fluid(s) with which the pump components come into contact.**

The user can contact the Manufacturer or the Distributor for suggestions concerning the construction materials that offer the best chemical compatibility; however, neither the Manufacturer nor the Distributor will be held liable for damage (malfunction, structural ageing, leakage or indirect damage) attributable to chemical incompatibility reactions between the pump materials and the fluids that come into contact with them.



## 1.3 INTRODUCTION TO THE MANUAL



The Original Instructions have been developed taking into account all sizes, the different supply configurations of the CUBIC series Air-operated Pumps, and the steps necessary for correct installation and safe use.

This manual is an integral part of the pump and a safety device by which the manufacturer intends to communicate important information so that the purchaser and their personnel install, use and maintain it in a constant state of efficiency and safety.

The processed information is aimed at pursuing the highest level of safety for the environment, the exposed people and the technicians qualified for the operations foreseen by the Manufacturer.

### CONSULTATION AND PRESERVATION

The Manufacturer's Original Instructions must always be kept in good condition and be available for consultation by the Technicians qualified to service the machine in which it will be installed.

Otherwise, the Manufacturer declines any liabilities concerning:

- Incorrect installation;
- Incorrect or missing assessments of chemical compatibility with the fluid to be pumped;
- Incorrect or missing assessments of classification of the potentially explosive environment and suitability for pump use according to the affixed Certification marking and the Declaration of Conformity;
- Improper use of the pump and/or for performances other than those declared;
- Use with higher temperatures than those declared by the Manufacturer;
- Interventions and/or use of the same by untrained personnel;
- Use contrary to the Manufacturer's safety rules;
- Serious deficiencies in maintenance;
- Changes or operations not authorised by the Manufacturer;
- Use of non-original spare parts and/or unsuitable parts for the pump;
- Total or partial non-compliance with the Manufacturer's Original Instructions.

### RECIPIENTS OF THE ORIGINAL INSTRUCTIONS

This Original Instructions manual is addressed to all Operators and Technicians qualified to transport, handle, install, maintain, and/or repair the pump.

All Operators and qualified Technicians who work on the pump must be aware of the service procedures established by the Manufacturer, of the residual risk present and of the safety measures to be taken to prevent dangerous situations, and any damage that may arise for exposed people and operators, as well as for the environment and property in general. In particular, Operators must be aware of all personal protective equipment to be used during operations that require working near potentially dangerous areas. The contents of this manual must be strictly followed.

### LIMITS OF THE ORIGINAL INSTRUCTIONS

Please note that the instruction manual cannot replace the adequate knowledge and technical preparation of the installer or maintenance technician. This Manual provides information and instructions on installation and maintenance that do not intend to replace or modify any general or specific standard, requirement or law concerning safety and use, which affects the machine on which the pump will be installed.

### UPDATES TO THE ORIGINAL INSTRUCTIONS

The manual reflects the state-of-the-art technique at the time of marketing the pump and cannot be considered inadequate only because it is not updated based on any and future technical achievements. The Manufacturer reserves the right to update production and the manual without prior notice and without obligation to update the previously issued documents.

## CONTENTS OF THE ORIGINAL INSTRUCTIONS

The topics are covered to allow a classification of the information and the professional address to which they are addressed so that the contained information can be immediately and directly consulted.

The manual is divided into chapters and related sections that deal with the operational topics for correct installation, use and maintenance of the pump, with exposure divided into numbered sequences.

The pages are characterised by the following layout and contents:

- A bar has been added at the beginning of each section which, through symbols, indicates the personnel authorised to operate, the prohibitions and obligations to be observed, and the Personal Protective Equipment (PPE) that must be used;
- The residual risk that may occur during the operations is highlighted by appropriate symbols integrated with the text.

Authorised Personnel

Title CHAPTER

Operational Sequences

Title SECTION

CAUTIONS WARNINGS and NOTES

Contents Graphs

Numbers PAGE

**2.4 DESCRIZIONE DELLA POMPA**

**2.4.1 PRINCIPIO DI FUNZIONAMENTO**  
La pompa pneumatica della serie CUBIC sono costituite da uno Scambiatore Pneumatico con un ridotto numero di componenti, che comanda tramite un unico controllo le membrane dei due gruppi pompanti. Le membrane solidali al primo controllo di trascinamento vengono azionate con moto alternato in due stadi (aspirazione-mandata) a combustione di elementi pompanti. Tra le due camere di pompaggio ed i condotti di aspirazione e mandata della pompa sono alloggiati le rispettive valvole a diaframma.

Il principio di funzionamento a doppio stadio avviene simultaneamente (mentre una camera è in fase di aspirazione, la seconda camera è in mandata) garantendo aspirazioni negative, prevalenze elevate e il pompaggio di fluidi con alta viscosità e parti solide in sospensione (vedere 2.7 CARATTERISTICHE TECNICHE).

**2.4.2 REQUISITI E CARATTERISTICHE DI INSTALLAZIONE**  
Le pompe pneumatiche della serie CUBIC sono autoadattabili e possono funzionare a secco e consentono la variazione della velocità di funzionamento anche durante il servizio. Possono essere impiegate per il ricambio e il pompaggio di liquidi con elevata viscosità e parti solide in sospensione (vedere 2.7 CARATTERISTICHE TECNICHE). Il loro funzionamento è previsto per installazioni in orizzontale, sopra e sotto banchine.

Le tubazioni di aspirazione e mandata devono essere opportunamente dimensionate (mai inferiori ai diametri della pompa) per garantire la portata minima ed un rendimento ottimale.

**2.5 USO PREVISTO E USI IMPROPRI**

**2.5.1 USO PREVISTO**  
Le pompe pneumatiche della serie CUBIC sono state progettate e costruite per il pompaggio di liquidi e fluidi aggressivi (acidi o alcalini) con composizione chimica e temperatura compatibili con i materiali di composizione della pompa a viscosità apparente compresa tra 1 a 20.000 Cps a 20°C (vedere Scheda Tecnica (Modello pompa)) per viscosità superiori a 20.000 Cps a 20°C intervengono fattori fisici che richiedono una corretta valutazione pertanto è sempre necessario contattare preventivamente l'Ufficio Tecnico del Costruttore.

La massima temperatura ammessa per fluidi di processo è comunque subordinata ed decisa dal materiale costruttivo della pompa e dell'impianto.

**ATTENZIONE**  
I limiti massimi di temperatura si basano su due fattori meccanici e corrosivi. Alcuni fluidi impiegati possono ridurre significativamente le temperature massime di sicurezza a causa dell'elevato tenore corrosivo. Con il superamento della massima temperatura, non è più garantita la conformità della marcatura ATEX apposta sulla pompa.

**2.5.2 CALCOLO DELLA MASSIMA TEMPERATURA DEL FLUIDO (per Zona 1 - Zona 21)**  
Gli di seguito viene indicata la formula per determinare la massima temperatura di processo del fluido consentita, per le pompe serie CUBIC in versione CONDUCT (selezione: II 22 GD + IB T135°C) per installazioni in Zona 1 - Zona 21.

Classe di Temperatura ATEX	Fattore di Calcolo (base per Zona 1 - Zona 21)	Massima Temperatura di Processo del Fluido
ATEX T4	Tx 55°C	T1 80°C

**4.3.4 ALLACCIAMENTO DEL CIRCUITO PRODOTTO**  
Dopo aver eseguito il posizionamento è possibile effettuare l'allacciamento della pompa al circuito del prodotto operando come segue:

**ATTENZIONE** pericolo di reazioni chimiche all'acqua  
Prima di effettuare l'installazione della pompa per l'impianto con liquidi che reagiscono con l'acqua di rubinetto è necessario effettuare l'apertura del circuito prodotto e provvedere all'asciugatura di tutte le superfici interne.

**Requisiti tubazioni impianto prodotto**

- I raccordi di allacciamento devono essere dello stesso materiale della pompa con filettature cilindriche (non impiegare filettature coniche).
- L'allacciamento alla pompa deve prevedere uno spezzone di tubo flessibile con anima metallica di adeguata elasticità e resistenza.
- Le tubazioni flessibili presenti devono essere rinforzate con anima metallica.
- Le tubazioni devono essere auto-sostenute e non gravare in nessun modo sulla pompa.
- Corretto dimensionamento dei condotti di aspirazione e mandata per una corretta velocità di aspirazione.
- Valvole di intercettazione prodotto (aspirazione e mandata, che non causino perdite di carico).
- Con partificio in sospensione, valutare sull'aspirazione una sacchettatura conestramente dimensionata (superficie 2,5 l) (volte la sezione di aspirazione della pompa con forza massima consentita).
- Con prodotti che cristallizzano prevedere un circuito di lavaggio (con prodotti compatibili).
- Condotti protetti dalle intemperie e privi di ree e parti di lavorazione (trucioli, partecolati, ecc.).

**4.3.4a** Le pompe a membrana con aspirazione negativa sono influenzate dai seguenti fattori:

- **Viscosità del fluido - peso specifico del fluido - diametro - lunghezza del serbatoio sull'aspirazione.** Posizionare la pompa il più vicino possibile al punto di prelievo (entro 2,5 m) e in tutti i casi mai superiore a 5 m verticalmente; il diametro del tubo di aspirazione non deve mai essere inferiore a quello dell'attacco della pompa; deve essere opportunamente dimensionato con l'aumentare della distanza o della viscosità del fluido.

**ATTENZIONE** pericolo di urto prematuro solo natura membranaria.  
Il fluido da pompare con aspirazione negativa non deve mai superare una viscosità di 5.000 Cps a 20°C ed un peso specifico di 1,4 Kg/l.  
Con viscosità superiori intervengono fattori fisici che richiedono una corretta valutazione pertanto è sempre necessario consultare preventivamente l'Ufficio Tecnico del Costruttore.

**4.3.4b** Le pompe serie CUBIC sono fornite con le sedi per attacco prodotto con filettature Gas cilindriche. Per le connessioni ai collettori della pompa impiegare unicamente raccordi con filettature Gas cilindriche (non coniche) dello stesso materiale della pompa.  
Esempio: (pompa in PP = raccordi in PP) oppure (pompa in INOX = raccordi in INOX).  
Installare sul collettore di mandata e scuro una valvola manuale di uguale diametro all'attacco della pompa (mai più piccola) o ingrandita per aspirazioni negative o per fluidi con elevata viscosità.  
Se necessario, caricare due giri di nastro in PTFE sul flutto ed avvitare le valvole sui collettori della pompa (con una forza di serraggio moderata) fino a garantire la tenuta.

Special symbols are used within the manual to highlight and differentiate particular information or suggestions important for the safety and/or correct installation, maintenance or replacement of the pump.

With these measures, the Manufacturer intends to draw the attention of qualified Technicians to the CAUTIONS, WARNINGS, or NOTES concerning them.

For any doubts or clarifications regarding the contents of this manual, do not hesitate to contact the Manufacturer's Technical Service.

Tel. +39 / 0331 074034  
 Fax +39 / 0331 074036  
 e-mail: info@debem.it  
 website: www.debem.com





## SYMBOLS AND DEFINITIONS



### MACHINE OPERATOR

Identifies the type of Operator in charge of the mentioned operation. This qualification requires having obtained the necessary training and specific skills in the sector of use of the pump, in addition to full knowledge and understanding of the information contained in the Manufacturer's user manual.



### HANDLING OPERATOR

Identifies the type of Operator in charge of the mentioned operation. This qualification requires specific skills for lifting equipment, safe methods and characteristics for slinging and handling as well as full knowledge and understanding of the information contained in the Manufacturer's user manual.



### INSTALLER/MECHANICAL SERVICEMAN

Identifies the type of Technician in charge of the mentioned operation. This qualification requires the necessary training and specific skills to carry out installation and maintenance works and full knowledge and understanding of the information contained in the manufacturer's user manual.



### EXTRAORDINARY PROCEDURES

Identifies the operations that can only be performed by the Manufacturer's After-Sales Service Technicians.

## HAZARD SYMBOLS

They indicate, together with the text, the type of residual risk that may occur during the mentioned operation:



**General danger.**



**Temperature hazard.**



**Danger of toxic and/or corrosive fluids.**



**Explosion hazard.**



**Danger of crushing and shearing.**

## PROHIBITION SYMBOLS

They indicate, together with the text, the type of prohibition to be observed during the mentioned operation:



Prohibition to come into contact with parts of the component when it is powered, running, or hot.



Prohibition to remove the guards with the pump powered or running.



Prohibition to lubricate.

## SYMBOLS AND DEFINITIONS

---

### OBLIGATION SYMBOLS

They indicate, together with the text, the type of personal protection to be used to carry out a certain operation:



Obligation to disconnect the power supply before intervening.



Obligation to wear gloves with toxic and corrosive fluids.



Obligation to wear protective and anti-slip shoes.



Obligation to wear aprons with toxic and corrosive fluids.



Obligation to wear a face mask with toxic and corrosive fluids.



Obligation to wear a respirator with toxic and corrosive fluids.

---



### CAUTION

It informs the personnel concerned that the operation described presents a residual risk of exposure to hazards with the possibility of personal injuries, harm to health, and/or the environment if not carried out in compliance with the requirements and procedures described and/or in the absence of the required suitable Personal Protective Equipment (PPE).



### WARNING

It informs the personnel concerned that the described operation may cause damage to the pump and/or its components and consequent risks for the Operator, Technicians and/or the environment if not carried out in compliance with the prescribed procedures.



### NOTE

It provides significant technical details relating to the topic and/or operation in question, the content of which is of technical importance or a technical/legal nature.

## 1.4 DELIVERY NOTE



The CUBIC series pumps are manufactured in accordance with Directive 2006/42/EC and 2014/34/EU in compliance with the harmonised European standards EN ISO 80079-36:2016, EN ISO 80079-37:2016.

By drafting this manual, the Manufacturer hopes that you will be able to make the most of the performance of CUBIC pumps, in complete safety; CUBIC pumps present no danger to the operator when used in accordance with the Manufacturer's Original Instructions.

It is the duty of the Client, the Installation and Maintenance Technicians and the Qualified Operators to take the necessary measures to ensure that access to the pump is restricted to trained and authorised personnel and to provide adequate information and warnings about any residual risk on the machine or system in which it will be installed, in accordance with current safety laws.

All technical values refer to 'standard' CUBIC pumps (*see 2.7 TECHNICAL FEATURES*) and please note that due to a constant search for technological innovation and quality, the reported technical features of the products may change without prior notice; **the version of the Original Instructions supplied with the pump must always be followed.**

It is forbidden to commission the pump before the machine in which it is to be incorporated has been declared compliant with the Machinery Directive 2006/42/EC provisions and any further applicable Regulations and/or Directives.

Please note that the Original Instruction Manual, the Drawings and any other technical documents delivered with the pump are confidential and the property of the Manufacturer, who reserves all rights (intellectual property) and PROHIBITS their reproduction (even partial, by any means) and disclosure to third parties without their prior written approval.

## 1.5 GENERAL NOTES ON DELIVERY



Upon receipt of the supply, check that:

- the packaging is intact;
- the supply matches the order specifications (*see accompanying document*);
- the pump has not been damaged.

DESCRIPTION OF THE SUPPLY	POS.
Pump	1
Official Manual (Original Instructions)	2

In the event of damage or missing parts, immediately inform (within 7 days of receipt) and in detail (possibly with photographs) the Manufacturer and the Carrier.

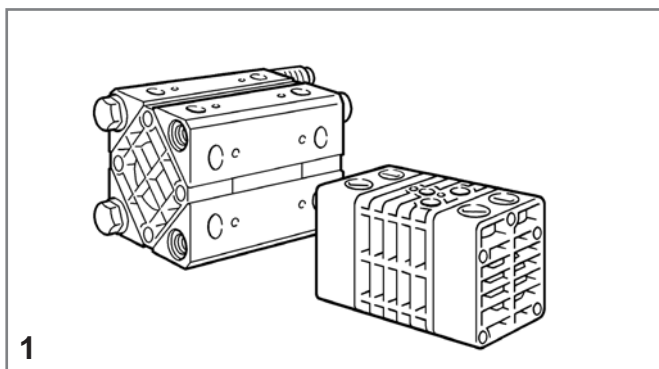

1



2

## 1.6 WARRANTY



The high quality of CUBIC pumps is promptly confirmed to us by our Customers' satisfaction. However, should any defect appear, please contact the Manufacturer's After-Sales Service, your Dealer or the nearest Customer Service Centre where you will receive assistance as quickly as possible.

### In any case, provide the following:

- A. Identification of the pump through the Serial number on the label affixed to it;
- B. Description of the detected anomaly.

### All CUBIC pumps are covered by the following warranty:

#### 1 WARRANTY TERMS

The pump is warranted for 12 months (8 hours of daily operation) starting from the delivery date (see Accompanying Document) on all mechanical parts found to be defective, except for the parts subject to normal wear due to operation. The warranty provides for free repair of the pump or the supply of replacement parts, provided that the manufacturer acknowledges the defect construction fault.

Repair or replacement of defective parts constitutes the full satisfaction of the warranty obligations.

#### 2 INTERVENTION NOTIFICATION

The Purchaser must report any defect to the Manufacturer in writing within 8 days.

#### 3 METHODS OF INTERVENTION

The warranty intervention will be exclusively carried out at the Manufacturer's workshop after the shipment or sending of the defective pump at the Purchaser's expense.

#### 4 EVALUATION RESERVE

Warranty shall not be extended in case of repair or replacement.

#### 5 EVALUATION RESERVE

The defective parts remain the Manufacturer's property the moment they are replaced by the same under warranty. If the parts are found not to be defective, the Manufacturer reserves the right to invoice the full cost of the parts replaced under warranty.

### Purchaser responsibility

The Manufacturer will not bear the costs and risks for the shipping or transport of the defective and/or repaired or replaced parts, including any customs charges. The warranty DOES NOT cover any indirect damage and, in particular, any lack of production. In addition, the warranty does not cover any normal consumable materials (diaphragms, balls and ball seats, etc.). The warranty does not cover parts damaged as a consequence of incorrect installation, carelessness, neglect, incorrect maintenance, or damages due to transportation or any other reason or event not directly linked to functional or manufacturing defects.

### Warranty and liability exclusion for chemical reactions:

Since an endless variety of products and chemical compositions of the fluids exists, the user is presumed to have the best knowledge of their compatibility and chemical reaction with the pump's construction materials. **The purchaser is strictly responsible for selecting the construction materials compatible with the fluid(s) with which the pump components come into contact.** The user can contact the Manufacturer or the Distributor for suggestions concerning the construction materials that offer the best chemical compatibility; however, neither the Manufacturer nor the Distributor will be held liable for damage (malfunction, structural ageing, leakage or indirect damage) attributable to chemical incompatibility reactions between the pump materials and the fluids that come into contact with them.

**The warranty excludes all cases of tampering, improper use or incorrect applications or non-observance of the information contained in the Manufacturer's Original instruction manual.**

**Any controversy falls within the jurisdiction of the Court of Busto Arsizio (VA) ITALY.**

# INTRODUCTORY INFORMATION



TRANSLATION OF ORIGINAL INSTRUCTIONS CUBIC - rev. 2022

## CHAPTER 2

This chapter of the manual covers topics of a preliminary nature but is especially important for the safe and correct use of the pump; therefore, follow the instructions in the sections below.

THIS PART INCLUDES THE FOLLOWING TITLES		PAGE
<b>2.1</b>	<b>PUMP IDENTIFICATION</b>	<b>14</b>
<b>2.2</b>	<b>PUMP CONFIGURATION CODE</b>	<b>15</b>
<b>2.3</b>	<b>ATEX MARKING AND DEFINITION</b>	<b>16 - 17</b>
<b>2.4</b>	<b>PUMP DESCRIPTION</b>	<b>18</b>
<b>2.5</b>	<b>INTENDED USE AND IMPROPER USES</b>	<b>18 - 19</b>
<b>2.6</b>	<b>TECHNICAL FEATURES</b>	<b>20 - 21</b>

Below is a detailed description of each topic mentioned.

## 2.1 PUMP IDENTIFICATION



- 2.1.1 For any communication with the Manufacturer or authorised After-Sales Centres, always specify the data shown on the identification plate of the pump.

### The identification plate contains the following data:

1. Manufacturer's Identification;
2. Manufacturer's address and contact numbers;
3. Pump name;
4. **Type and Composition Code of the pump;**
5. **ATEX Marking;**
6. Identification code (serial number);
7. Year of manufacture:

### ATEX: STANDARD - CONDUCT version

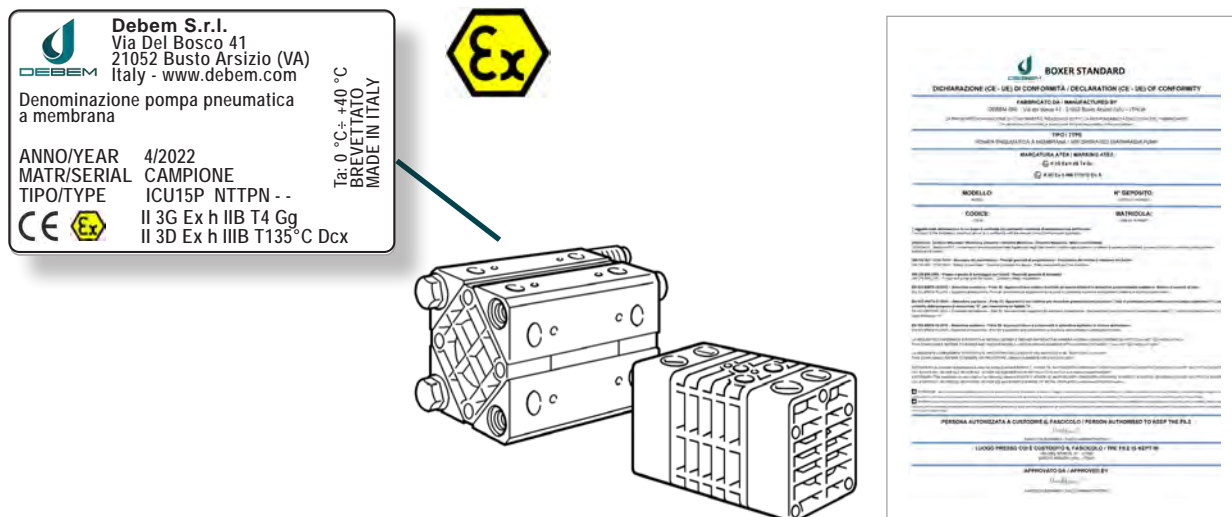

### CAUTION

The nameplate and Declaration of Conformity contain highly important data, allowing the pump's material composition to be recognised (**4. Type and Composition Code of the pump**) essential to properly assess the chemical compatibility with the fluid to be used. The data shown indicate the ATEX execution class (**see ATEX marking**) for the correct assessment of compatibility with the working environment.

**IT IS FORBIDDEN to remove and/or alter the identification plate and the data it contains; removal involves forfeiture of the warranty.**

- 2.1.2 The number of this manual is written on the cover. Make a note of the revision code and keep it so that you can request a new copy in case of loss.

## 2.2 PUMP CONFIGURATION CODE



CUBIC series Air Pumps have been designed and manufactured in different configurations (composition materials).

The identification plate of the pump contains the product model, which also specifies the composition materials of the pump, which is reported and explained below in order to determine the suitability and compatibility of the pump with the fluid to be pumped and the surrounding environment.



**CAUTION: risk of damage and product leakage.**

Please note that the pump must always be installed in compliance with the characteristics of the pump composition materials shown on the Identification plate (see sections 2.2 CONFIGURATION CODE and 2.7 TECHNICAL FEATURES).

**It is always necessary to check the suitability of the chemical compatibility and temperature of the fluid to be pumped (if necessary, by subjecting it to prolonged tests) before installing and using the pump.**

**Example of Pump Configuration Code:**

IMID-	P -	N	T	A	R	T	--	C
PUMP MODEL	PUMP BODY	AIR SIDE DIA-PHRAGM	FLUID SIDE DIAPHRAGM	BALLS	BALL SEATS	O-RING	MANIFOLD	VERSION
IMID - MIDGETBOX ICU15 - CUBIC 15	P PP E ECTFE PC PP+CF	N NBR	T PTFE	G Pyrex <sup>®1</sup> D EPDM <sup>2</sup> A AISI 316L T PTFE <sup>2</sup>	R PPS <sup>1</sup> K PEEK <sup>1</sup> P PP <sup>2</sup> E ECTFE <sup>2</sup> A AISI 316L <sup>2</sup> I PE - HMW	D EPDM <sup>2</sup> V Viton <sup>®2</sup> N NBR <sup>2</sup> T PTFE	X Manifold split Y NPT thread	C = CONDUCT for ATEX Zone 1 

1 : For MIDGETBOX only;  
2: only for CUBIC 15;

\* : MIDGETBOX only mounts PTFE O-rings.

## 2.3 ATEX MARKING AND DEFINITION



All the CUBIC series Air-operated pumps comply with the Community Directives for the free movement of goods applicable to them (see *Declaration of Conformity*).

They are produced as standard in the STANDARD version in ATEX execution **Ex II 3G Ex h IIB T4 Gc** and **Ex II 3D Ex h IIB T135°C Dc X** for use in "Zone 2- Zone 22" (in the presence of flammable gas and dust) and in ATEX execution **Ex**.

Upon specific request in the order phase, pumps can be supplied in the CONDUCT version in ATEX execution **Ex II 2G Ex h IIB T4 Gb** and **Ex II 2D Ex h IIB T135°C Db X** for use in "Zone 1 - Zone 21".

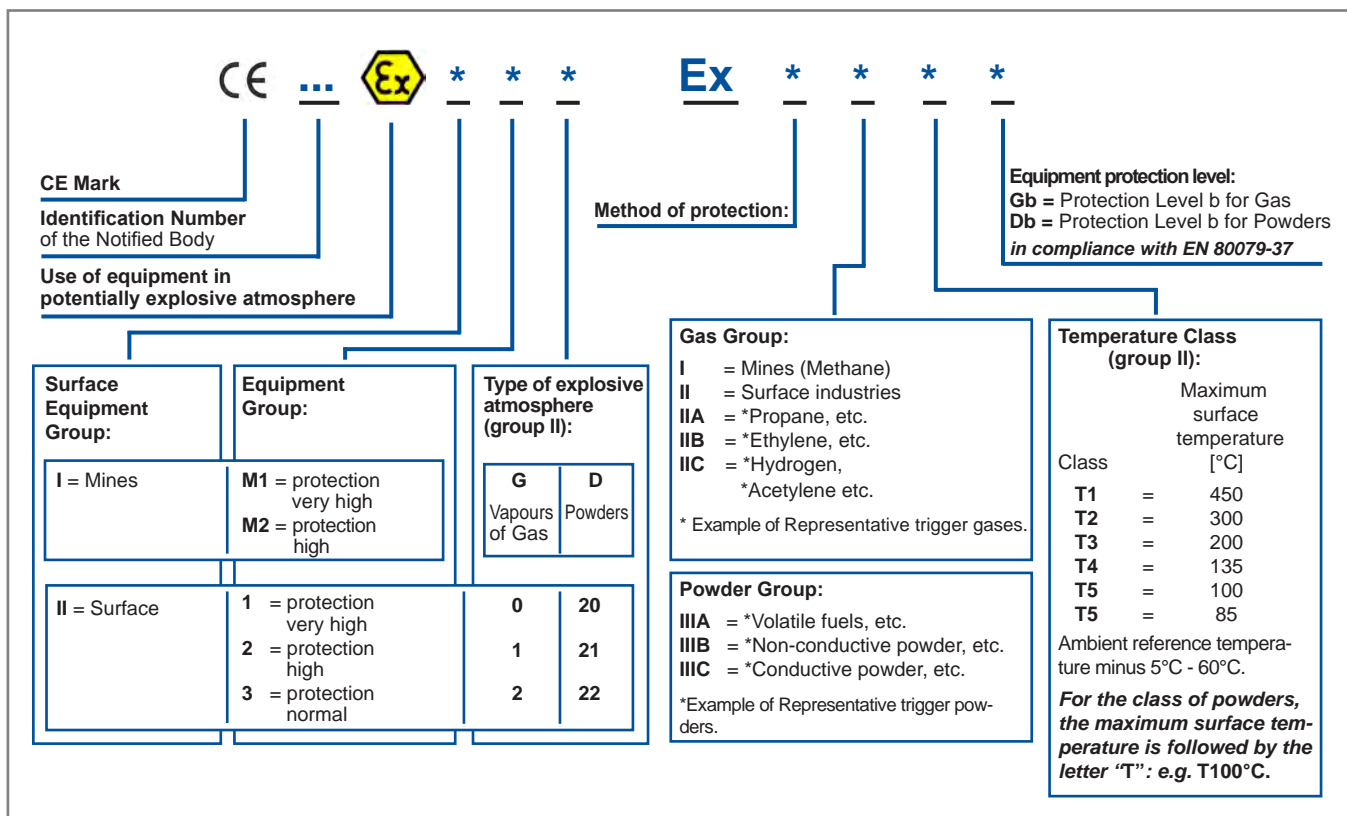

### CAUTION

The Identification Plate of the pump shows the ATEX marking and the category of the equipment. **Check compliance with the classification of the installation "Zone" before carrying out the installation. The equipment user is responsible for classifying their installation zone.**

Below is the definition of the ATEX marking of each execution.



: safety symbol in accordance with DIN 40012 attachment A.

**II 3G/II 3D**: surface equipment for use in areas with the presence of gases, vapours or mists in addition to clouds of combustible dust in the air that occur occasionally during normal operation, both in external and internal areas (Zone 2 - Zone 22)

**II 2G/II 2D**: surface equipment for use in areas with the presence of gases, vapours or mists in addition to clouds of combustible dust in the air that occur occasionally during normal operation, both in external and internal areas (Zone 1 - Zone 21).

**Ex h**: Protection equipment «c», or «b», or «k», in accordance with EN 80079-37.





- IIB** : excluding the following gases: hydrogen, acetylene, carbon disulphide.
- IIIB** : excluding the following powders: conductive powder.
- T4/T135°C** : class of admitted temperatures. The processed fluid temperature value must fall within such class range and the user must comply with the instructions contained in the manual and with the current laws. Furthermore, the user must take into account the ignition points of the gases, vapours and mists in addition to clouds of combustible powder in the air existing in the area of use.
- Gb** : Protection level b for Gas according to EN 80079-36:16.
- Db** : Protection level b for Dust according to EN 80079-36:16.
- X** : The internal area of the pump is not ATEX, that is, it cannot process powders.

**The Technical File is deposited with TÜV NORD CERT of Hannover.**

## 2.4 PUMP DESCRIPTION



### 2.4.1 OPERATING PRINCIPLE

CUBIC Air-operated pumps consist of a Pneumatic Exchanger with a reduced number of components, which controls the diaphragms of the two pumping units via a central pin. The diaphragms integral with the central driving pin are operated with alternating motion in two stages (suction-delivery) and constitute the pumping elements.

The respective ball valves are housed between the two pumping chambers and the pump delivery and suction ducts.

The dual-stage operating principle takes place simultaneously (while a chamber is sucking, the second chamber is delivering), ensuring negative suctions, high heads and pumping of fluids with high viscosity and solid parts in suspension (*see 2.7 TECHNICAL FEATURES*).

### 2.4.2 INSTALLATION REQUIREMENTS AND FEATURES

CUBIC Air-operated pumps are self-priming and can run dry and allow varying the operating speed even during service.

They can be used for the recirculation and pumping of liquids with high viscosity and solid parts in suspension (*see 2.7 TECHNICAL FEATURES*). Their functioning is designed for horizontal positive and negative suction installations.

The suction and delivery pipes can be suitably sized (never smaller than the pump) to ensure minimum flow rates and optimal performance.

## 2.5 INTENDED USE AND IMPROPER USES



### 2.5.1 INTENDED USE

The Air-operated CUBIC pumps have been designed and constructed to pump liquids and aggressive liquids (acid or alkaline) with chemical composition and temperatures compatible with the pump materials and apparent viscosity of between 1 and 20,000 Cps at 20°C (*see the Technical Data Sheet of the Pump model*); **physical factors intervene for viscosities higher than 20,000 Cps at 20°C that require a correct evaluation, therefore, it is always necessary to contact the Manufacturer's Technical Department in advance.**

The maximum temperature allowed for process fluid depends on and/or is adjusted based on the construction material of the pump and system.



#### CAUTION

The maximum temperature limits are based on two factors, mechanical and corrosive. Some of the fluids used may significantly reduce the maximum safety temperatures due to the high corrosive content. **Conformity with the ATEX marking affixed on the pump is no longer ensured when the maximum temperature is exceeded.**

### 2.5.2 CALCULATION OF THE MAXIMUM FLUID TEMPERATURE (for Zone 1 - Zone 21)

Below is the formula for determining the maximum permissible fluid process temperature for CUBIC series pumps in CONDUCT version: II 2/2 GD c IIB T135°C) for installation in Zone 1 - Zone 21.

Temperature Class ATEX		Calculation Factor (only for Zone 1- Zone 21)		Maximum temperature of Fluid process
ATEX T4	-	Tx 55°C	=	Tf 80°C



### 2.5.3 TEMPERATURE CLASS PUMPS TO BE INSTALLED IN EXPLOSIVE ENVIRONMENT (Zone 1):

The temperature class corresponding to the protection against the risk of explosion of the pumps designed for use in Zone 1 with the presence of explosive atmospheres is T135°C (T4); all the data for calculating the maximum fluid temperature under the operating conditions are shown below.



#### NOTE

The equipment's maximum temperature has been determined with no powder deposits on the external and internal surfaces.

#### Definition of the Calculation Data (Zone 1):

- T4** = ATEX temperature class 135°C;
- Ta** = maximum ambient temperature 40°C;
- Tl** = maximum temperature for dry use of the pump in the workplace (50°C);
- Δs** = safety factor (5°C);
- Tx** = calculation factor (Tl + Δs) only for Zone 1;
- Tf** = maximum allowed fluid processing temperature.



#### CAUTION

In consideration of the admitted ambient temperature variation range in Zone 1, fluid service temperature values higher than those indicated above will not permit compliance to the corresponding temperature class, T4 (135°C).

**Where the user presumes that the temperature limits set forth on the product marking and in this manual may be exceeded, a detection and protective device must be installed on the system to prevent the maximum allowed temperature from being reached.**



#### NOTE

The user must consider the ratio between the pump's maximum surface temperature indicated on the marking and the minimum ignition temperature of the layers and clouds of powder.

### 2.5.4 IMPROPER USES

Any use of the CUBIC series pump other than that described above and specified in [Section 2.7 TECHNICAL FEATURES](#) is considered improper and therefore prohibited by the manufacturer DEBEM.

#### In particular, it is prohibited to use the CUBIC series pump for:

- production of vacuum;
- operation as a shut-off valve, as a check valve (non-return valve), or as a metering valve;
- pump operation with powders of all types and kinds (flammable and non);
- use with fluids that are chemically incompatible with the materials of construction;
- operation with air pressures, process temperatures and/or functional characteristics that are incompatible with the Technical Data of the pump and/or the Certification marking affixed;
- pump operation in potentially explosive environments that are not classified and/or compatible with the type of execution of the pump ([see Certification marking affixed and Declaration of Conformity](#)).
- unsuitable pump use (incorrect choice of materials and installations) to operate in the presence of stress corrosion cracking phenomena;
- operation with alimentary or pharmaceutical fluids.



#### CAUTION

The risks associated with the use of the pumps under the exact conditions outlined in the Manufacturer's use and maintenance manual have been analysed, whilst the analysis of the risks associated with the interface with other system components must be carried out by the installer/user.

**Use of the pump that does not comply with the Manufacturer's Original Instructions is prohibited and invalidates the Warranty and the safety and explosion protection requirements.**

## 2.6 TECHNICAL FEATURES



The technical performance data of the CUBIC series pumps refer to standard executions. The 'MAX flow rate' values refer to pumping water at 20°C with an immersed suction pipe with a head of 50 cm (see figure 1). The "Suction Capacity" values are measured with a vacuum gauge.



### NOTE

the declared capacity of dry negative suction refers to the intake of fluids with a viscosity and specific weight equal to 1. The performance and duration of the pump's diaphragms depend on the following factors:

- the fluid's viscosity and specific weight;
- the length and diameter of the suction pipe and/or presence of suction bends on the product circuit;
- presence of abrasive solid particles.

**NEGATIVE SUCTION:** with fluids max up to 5,000 Cps at 20°C and a maximum specific weight of 1.4 Kg/l.

**POSITIVE SUCTION:** with fluids max up to 20,000 Cps at 20°C (see Pump model).

**With higher viscosities, physical factors intervene that require a correct evaluation; therefore, it is always necessary to contact the Manufacturer's Technical Department in advance.**

The following tables show the Technical Data, the maximum overall dimensions, the clamping points and the weights; **for the dimensional values and the specific technical data of the supply, see the Technical Data Sheets of the specific model.**

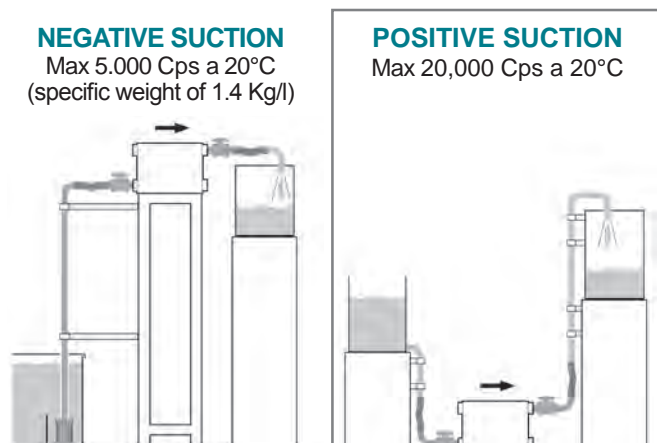
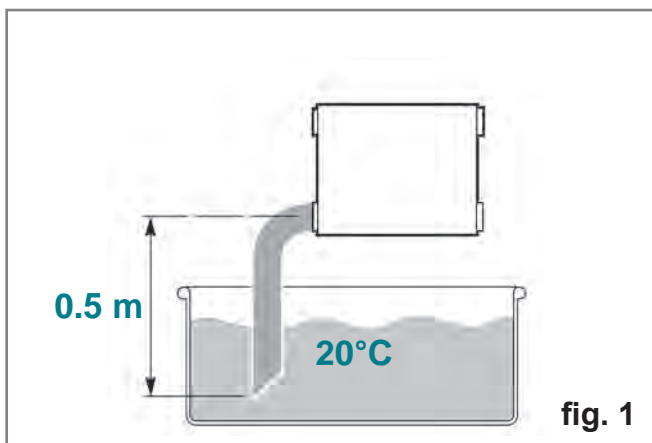

TECHNICAL DATA		unit of measurement	MIDGETBOX	CUBIC 15
Suction/delivery fittings		inches	1/4" f	3/8" f
Air fitting		inches	1/8" f	3/8" f
Air pressure (MIN-MAX)		bar	2 - 8	2 - 8
Solids passing MAX		∅ mm	0	0.5
Dry suction capacity (PTFE diaphragm)		m	3	3
Max head (water 20°C)		m	80	80
MAX water flow rate 20°C (immersed suction manifold)		l/min	6	17
MAX fluid temperature (zone 2 - 22)	PP (zone 2 - 22)	°C	65	65
	ECTFE (zone 1 - 22)	°C	--	95
MAX fluid temperature (zone 1 - 21)	PP+CF (zone 1 - 21)	°C	65	65
	ECTFE (zone 1 - 21)	°C	--	95
Weight (empty)	PP	Kg	0.52	1.35
	ECTFE	Kg	--	1.6
	PP+CF	Kg	0.52	1.35
Noise (5 bar rubber balls)		dB (A)	60	65



### MIDGETBOX pump

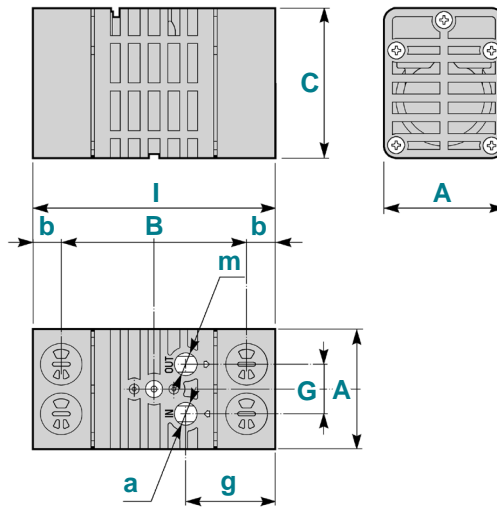

### CUBIC 15 pump

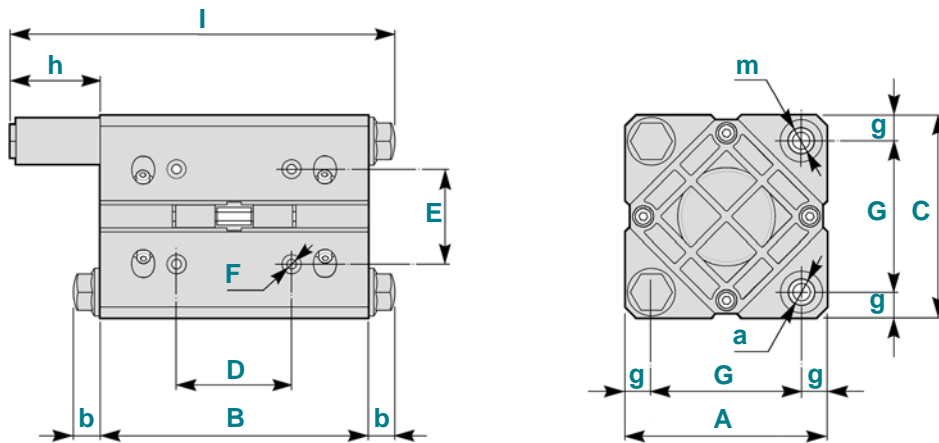

PUMP	MATERIAL	WEIGHT Kg	inches		DIMENSIONS mm										
			a	m	A	B	b	C	D	E	F	G	g	h	I
MIDGETBOX	PP	0.52	1/4" f	1/4" f	60	93.6	14	75	--	--	--	25	44.8	--	122
MIDGETBOX	PP+CF	0.52	1/4" f	1/4" f	60	93.6	14	75	--	--	--	25	44.8	--	122
CUBIC 15	PP	1.35	3/8" f	3/8" f	105	140	14	105	60	49	M6	78.5	13.4	47	201
CUBIC 15	PP+CF	1.35	3/8" f	3/8" f	105	140	14	105	60	49	M6	78.5	13.4	47	201
CUBIC 15	ECTFE	1.6	3/8" f	3/8" f	105	140	14	105	60	49	M6	78.5	13.4	47	201



## CHAPTER 3

This chapter deals with very important safety issues and how to safely install, use, or maintain the CUBIC pumps.  
Strictly follow these simple principles and rules throughout the life of the pump.

THIS PART INCLUDES THE FOLLOWING TITLES	PAGE
<b>3.1 SAFETY RULES</b>	<b>23 - 26</b>

The following sections describe how to behave.

## 3.1 SAFETY RULES



The Original Instructions must always be available to operators. Dangerous or hazardous practices or interventions not complying with the Safety Rules and with the recommendations contained herein may cause material damage, serious injuries and, in extreme cases, even death for which the Manufacturer cannot be held responsible.

- 3.1.1 All pumps undergo functional tests and are tested with water at 20°C before being shipped to the Customer; therefore, tap water residues can be found inside them.



**CAUTION: risk of chemical reactions with water**

Before installing the pump for use with liquids that react with tap water, it is necessary to open the product circuit and dry all internal surfaces.

- 3.1.2 The personnel in charge of installing, inspecting and maintaining the pump must have suitable technical preparation and knowledge of the product to be pumped and on potentially explosive atmosphere and related risk for uses in ATEX areas.



**CAUTION**

These instructions are essential for the pumps' compliance with the requirements of the 2014/34/EU and must therefore be available, known, understood and used by all Operators.

- 3.1.3 Use of the pumps in a manner that does not comply with the instructions indicated in the Manufacturer's use and maintenance manual will cancel all the requirements for safety and protection against explosions.



**CAUTION**

The maximum allowed temperature for process fluids (in zone 1 and zone 21) is equal to 65°C or 95°C depending on the construction materials of the pump; **if exceeded, compliance with the affixed ATEX marking is not ensured.**

- 3.1.4 The air supply to the pump must always entail the installation of a suitable on-off valve (Emergency), 3-way valve and check valve, and the pressure must never be less than 2 bar or greater than 8 bar. The pneumatic motor of the CUBIC pumps is self-lubricated (no further lubrication is required); feed the pump with dry and NON-lubricated filtered air. It is FORBIDDEN to feed the pump with lubricated, unfiltered and/or undried air.



**CAUTION: danger of fluid entering the compressed air circuit and being discharged into the environment.**

Installation of the pump without a shut-off valve, 3-way valve, and check valve on the air supply line is prohibited to prevent the pumped fluid from entering the pneumatic circuit in the event of a diaphragm rupture. Even in battery installations, the check valve must be installed on each pump.

- 3.1.5 The air of the pump's pneumatic circuit must always be discharged in a free, non-dusty atmosphere and free of saturated vapours that can damage the internal circuit.



**CAUTION: danger of damage to the internal pneumatic circuit.**

For installations with the pump immersed or operation in environments with a heavy atmosphere (dust, vapours or saturated vapours), it is necessary to install a pipe and fittings (of suitable materials) to bring the air discharge point outside the environment/process liquid.

- 3.1.6 Pump installations with high delivery heads, very dense fluids, high specific weight, and/or high back-pressures may cause the pneumatic circuit outlets to freeze.



**CAUTION: danger of air discharge outlet freezing and loss of efficiency and/or pump shutdown.**

Provide for the installation of a glycol adder on the air supply line, upstream of the pump.

- 3.1.7 Where the user presumes that the temperature limits set forth in this manual may be exceeded, a protective device must be installed on the system to prevent the maximum allowed temperature from being reached.



**ATTENTION: danger of loss of conformity with the ATEX marking affixed.**

It is forbidden to use the pump at temperatures higher than those permitted and specified in the manual; **if the maximum temperature is exceeded, conformity with the marking is not guaranteed.**



- 3.1.8 It is always necessary to thoroughly check the suitability of the chemical compatibility and temperature of the fluid to be pumped (if necessary, by subjecting it to prolonged tests) before installing and using the pump..



**CAUTION: danger of chemical reactions and possible breakage or product leakage.**

It is forbidden to use the pump with fluids that are not compatible with the component materials.

- 3.1.9 Loads that burden the pump, together with fluids or uses in corrosive environments in contact with some materials, can cause stress corrosion cracking (material deterioration due to the combined action of corrosion and application of a constant load). This often leads to sudden and unexpected breakage (not attributable to construction defects) of the components subjected to stress in corrosive environments, especially with high temperatures.



**CAUTION: danger of stress corrosion cracking and sudden breakage with product leakage.**

In the presence of stress corrosion cracking, the user must check complete compatibility (over time) with the construction materials of the pump or, if necessary, make a more suitable choice of construction material and follow the Manufacturer's instructions during the installation to eliminate the loads.

- 3.1.10 The CUBIC series pumps are not self-draining, so when used with crystallising fluids, once stopped it is always necessary to promptly flush the pump internally with suitable clean flushing fluid.



**CAUTION: danger of pump shutdown.**

The prolonged shutdown of the pump containing fluids that crystallise can cause the valves and diaphragms to stick and malfunction.

- 3.1.11 When using the pump with aggressive or noxious liquids that may represent a health hazard, you must install suitable protection on the pump to contain, convey and collect the product in a safe area and signal any spills.



**CAUTION: danger of pollution, contamination, injuries or, in extreme cases, death.**

It is forbidden to install the pump in the absence of suitable protection for the containment and collection of aggressive or toxic liquids or liquids that may represent a health hazard.

- 3.1.12 Installation requires suitable valves (with a larger diameter than the pump) for the interception and sectioning of the product upstream and downstream of the pump to allow safe operation in case of anomalies and/or disassembly.



**CAUTION: danger of uncontrolled product leakage.**

Installing the pump without suitable on-off valves on the intake and delivery sides is forbidden.

- 3.1.13 The pump does not perform valve functions and does not ensure the seal against the non-return of the fluid. In the event of installation with a high delivery head and/or a fluid of high specific weight, it is necessary to install a suitable check valve (suitably sized) on the duct near the pump.



**CAUTION: danger of uncontrolled product leakage.**

Installations with a high delivery head and/or a fluid of high specific weight can generate strong back-pressures that prematurely wear the diaphragms and/or cause a possible breakage.

- 3.1.14 In installations where the presence of solid particulate suspended in the product is expected, install a suitable strainer on the suction inlet, with a surface area of 2.5 or 3 times the area of the suction pipe and passages smaller than the size of the particulate allowed by the pump.



**CAUTION: risk of damaging the pump**

Installing the pump without a suitable strainer or with an insufficient and undersigned fluid flow rate and/or passage larger than the particulate allowed by the pump model is forbidden.

- 3.1.15 In general, all fittings, ducts, valves, and/or filters installed along the entire air circuit and product circuit, upstream and downstream of the pump, must never have a flow rate lower than the nominal values of the pump.



**CAUTION: risk of diaphragm rupture and product leakage**

In addition to determining poor efficiency and performance, the presence of flow rate points lower than the nominal values of the pump along the product circuit ducts, upstream and downstream of the pump, can prematurely wear the diaphragms and/or cause breakage.





- 3.1.16 To install the pump, use fittings with cylindrical gas threads made of the same construction material as the pump. In general, all the pump threads for connection with the fluid suction and delivery ducts are not intended to ensure hydraulic seal; to ensure a hydraulic seal, use suitable seals.



**CAUTION: risk of thread breakage and product leakage.**

It is forbidden to use fittings with tapered threads or made with a construction material other than that used for the pump.

The tightening of the suction and delivery fittings must ensure the mechanical seal of the ducts while to ensure the hydraulic seal, use suitable seals.

- 3.1.17 Using the pump in a potentially explosive environment must always provide for efficient earthing, regardless of any organ connected to it. When pumping flammable liquids (allowed by the marking), it is essential to use suitable "CONDUCT" pumps with the ATEX marking, with appropriate earthing.



**CAUTION: risk of explosions due to electrostatic charges.**

Lack of earthing or incorrect earthing of the pump will cancel the requirements for safety and protection against the risk of explosion provided for by the affixed ATEX marking. It is forbidden to use pumps made of non-conductive material (which is electrostatically charged) for flammable liquids and/or without adequate earthing.

- 3.1.18 The presence of vortices on the suction point results in cavitation and malfunction. During operation, check for any abnormal noise and make sure the outlet fluid does not contain "gas".



**CAUTION: in the event of abnormal noise, stop the pump immediately.**

Abnormal noise or the presence of "gas" in the fluid exiting the pump indicate an anomalous condition for which it is always necessary to determine the cause before continuing use.

- 3.1.19 Depending on the place of installation of the pump and the duration of exposure near it, it is necessary to detect the emitted noise.



**CAUTION: risk of exposure to noise.**

If necessary, use suitable sound-absorbing barriers and/or Personal Protective Equipment (such as sound-absorbing plugs or earmuffs).

- 3.1.20 The diaphragms, (internal and in contact with the product) are components subject to wear. Their duration is strongly affected by the conditions of use and by the chemical and physical stresses to which they are subjected. From tests carried out on thousands of installed pumps (with heads equal to 0.5 m at 20°C), it was found that the duration exceeds 100,000,000 (one hundred million) cycles.



**CAUTION: risk of diaphragms rupture.**

For safety reasons, the pump diaphragms must be disassembled and checked **every 10,000,000 (ten million) cycles and their replacement every 20,000,000 (twenty million) cycles.**

- 3.1.21 The operation of the pump must be adjusted only by choking the supply of compressed air through the adjustment valve or flow regulator.



**CAUTION: risk of premature wear and/or diaphragm rupture.**

It is forbidden to close or choke the sectioning valves of the product suction duct during pump operation. Changing the general performance and head of the pump and/or subjecting the diaphragms to strong stress affects their duration.

- 3.1.22 The pneumatic exchanger components (shaft included) are built with materials that are not specifically resistant to chemical and corrosive products; if the diaphragms break, the fluid can enter the pneumatic exchanger and the environment through the discharge circuit and damage the components.



**CAUTION: damage of the pneumatic exchanger.**

If the diaphragms rupture, and come into contact with corrosive fluid, it is necessary to completely replace the pneumatic exchanger.

- 3.1.23 The presence of dust and/or deposits on the external and internal surfaces of the pump can negatively affect the process temperatures. In environments with a potentially explosive atmosphere, it can even compromise safety and cancel the requirements envisaged by the affixed ATEX marking.

The pumps must not be installed and/or exposed to sand and/or pressurised abrasive material that could damage the external plastic parts.

**CAUTION: risk of overheating and/or fire**

It is necessary to periodically verify the absence of dust and/or deposits from the external and internal surfaces of the pump and, if necessary, remove and clean them with a damp cloth. It is forbidden to use the pump with powders and dehydrated and/or solid materials of any type and kind (flammable and non).

- 3.1.24 The silencer and the compressed air supply fitting must be disassembled in the absence of dust. Before disassembling, clean the outside of the pump to prevent deposits and impurities from entering the air circuit.

**CAUTION: risk of damage to the pneumatic exchanger.**

Before reassembling the silencer and the compressed air supply fitting on the pump, make sure that no deposited impurities or dust enter the pneumatic distributor of the pump.

- 3.1.25 In severe conditions, the pump can reach significant external temperatures (Max 70°C) during its intended operation; in these cases, it is necessary to provide a suitable guard and/or marking to signal the residual risk.

**CAUTION: risk of high temperatures and/or burns.**

Before intervening or coming into contact with the external surfaces of the pump, it is recommended to wait for it to cool and/or wear protective gloves.

- 3.1.26 Before disassembling the pump, the residual pressure of the internal pneumatic circuit must always be discharged by operating as described in Section "5.2 PUMP STOP".

**CAUTION: risk of internal back-pressures and projection of components during disassembly.**

In abnormal conditions (incorrect installation and/or shutdown and/or standstill conditions), residual pressure, which is not relieved, may be generated inside the pump. Before opening and disassembling the pump, it is necessary to secure the pump casings with suitable ratchet straps.

- 3.1.27 Aggressive, toxic, or dangerous fluids can cause serious physical injuries and/or dangerous harm to health. Always wash and empty the internal circuit of the product and wash and treat the pump before disassembling, storing, and/or shipping it to the Manufacturer.

**CAUTION: risk of injuries or harm to health.**

It is forbidden to disassemble, store, and/or return the pump with residue of aggressive, toxic or dangerous product, or not properly washed and decontaminated to the Manufacturer or a Service Centre. Always fill in and affix the washing form on the pump (see 8.1.4 PUMP WASHING FORM) after treatment and before shipment; the absence of the form or failure to fill it in will result in NON-CONFORMITY in acceptance.

In addition to performing their primary function, the components of the CUBIC pumps are designed and built to meet important functions that affect the general safety of the pump; **use only Original spare parts to replace worn parts.**

**Failure to comply with the above may result in dangers for the Operator, Technicians, people, the pump and/or the installation environment, for which the Manufacturer is not responsible.**

# TRANSPORT AND POSITIONING



TRANSLATION OF ORIGINAL INSTRUCTIONS CUBIC - rev. 2022

## CHAPTER 4

CUBIC pumps are normally shipped in a cardboard box or, at the Customer's request and the place of dispatch, they can be supplied on pallets with wooden crates or in packaging for shipment by sea.

THIS PART INCLUDES THE FOLLOWING TITLES		PAGE
4.1	STORAGE AND PRESERVATION	28
4.2	TRANSPORT AND HANDLING	29
4.3	POSITIONING AND INSTALLATION	30 - 33
4.4	PNEUMATIC CONNECTION	34 - 36
4.5	CHECKS BEFORE COMMISSIONING	36

Below is a description of how to behave in each of the cases described above.

## 4.1 STORAGE AND PRESERVATION



CUBIC pumps are normally shipped in a closed cardboard box with internal cardboard shockproof protection.

Upon specific customer request, depending on the quantity and country of destination, they can be shipped on pallets, in wooden crates or with packaging for shipments by sea.

The packaged pump can be stored for up to 6 months in a marine environment (protected, dry and clean) and 12 months in a terrestrial environment (clean, protected and dry), at temperatures from +5°C to +45°C, with relative humidity not exceeding 90%.

Upon delivery, check that the packaging and the pump are intact and undamaged; then, you can arrange for storage or assembly.

### 4.1.1 OPERATIONS FOR FUTURE STORAGE

Subsequent storage of the pump must always be carried out with the pump empty, without liquids, and after it has been properly flushed.

4.1.1a Drain the pump of any liquid residues.

4.1.1b Wash the internal and external surfaces of the pump and provide for its decontamination if dangerous or toxic liquids have been used.



**CAUTION: risk of pump damage.**

The pump must be stored in suitable packaging, protected from sunlight and dust, and away from substances that react with the construction materials.

### 4.1.2 INTERVENTION AFTER PROLONGED STORAGE/STOPS, BEFORE OPERATION

After prolonged storage and/or stop, it is always necessary to perform the following checks before commissioning the pump:

4.1.2a Check the tightness of the pump screws as described in [Section 6.3 TIGHTNESS CHECK](#).



**CAUTION: risk of damage and breakages.**

Excessive tightening (especially on plastic pumps) can cause dangerous tensions on some components and/or sudden breakages that cannot be attributed to construction defects.

4.1.2b Carry out an initial check of the pump's no-load operation and pay attention to the correct operation of the pneumatic exchanger and the absence of abnormal noises.



**CAUTION: in the event of abnormal noise, stop the pump immediately.**

An abnormal noise from the pump indicates an irregular condition for which it is always necessary to determine the cause before continuing; **in such cases, immediately stop the pump and resolve the anomalous condition before commissioning.**

## 4.2 TRANSPORT AND HANDLING



These operations are only reserved for handlers with appropriate Personal Protective Equipment (PPE), such as protective gloves, safety shoes and protective clothing.



### **CAUTION: risk of tipping and crushing.**

The load inside the packaging can be unbalanced, therefore, do not use lifting equipment and gripping points other than those indicated on the packaging.

When the supply is received, check that the packaging and the pump are intact and have not been damaged, then:

4.2.1 Lift the supply using hoists of adequate capacity for the weight, respecting the instructions on the packaging. Handle the supplied items with slow movements, keeping them at a minimum height from the ground and place them at the place of installation (dry and covered). Remove the hoist.

4.2.2 Open the packaging, retrieve the use and maintenance manual, and work as described.



### **CAUTION: danger of pollution.**

Do not disperse the packaging into the environment but contact specifically authorised disposal companies.

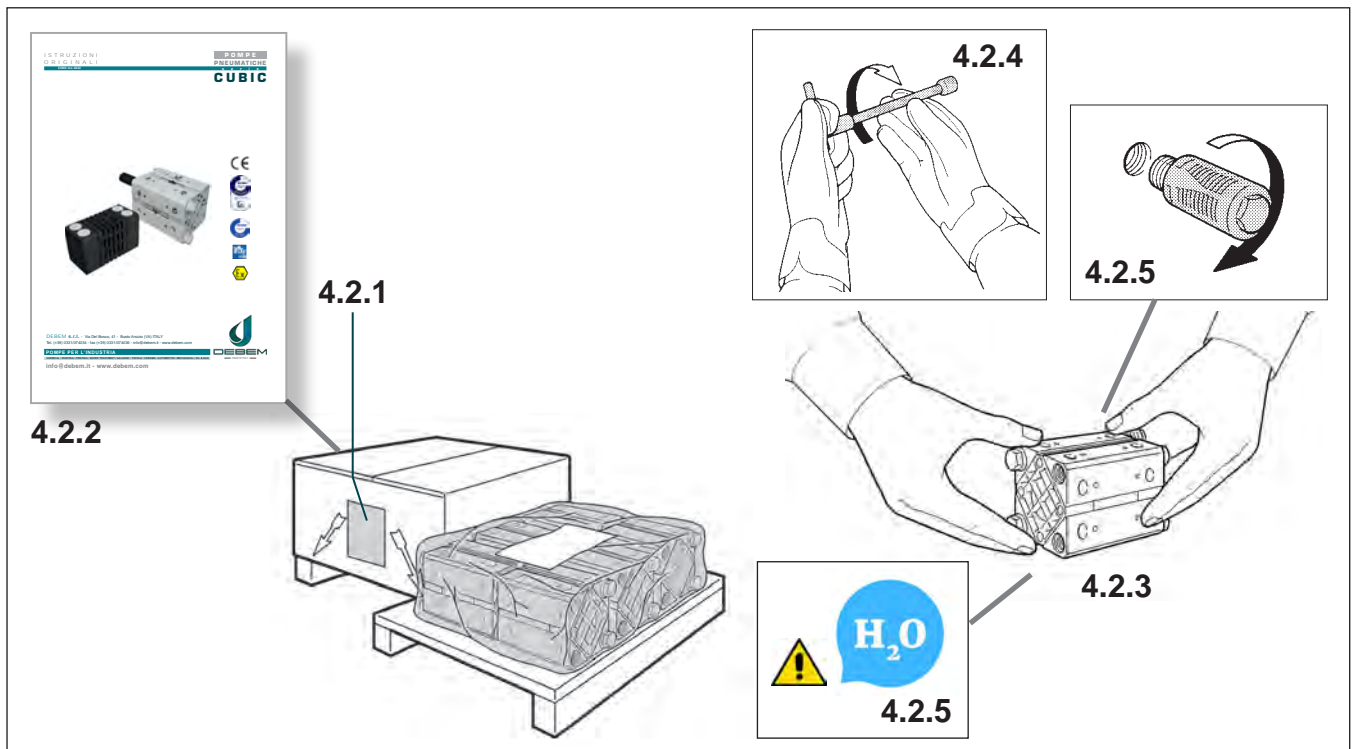

4.2.3 Lift the pump and place it on a clean surface in a protected environment.

4.2.4 Check that all the pump screws are tight, respecting the tightening torques shown in [Section 6.3 TIGHTNESS CHECK](#).



### **CAUTION: risk of stress corrosion cracking phenomena and breakages.**

Excessive tightening (especially on plastic pumps) can cause dangerous tensions on some components and sudden breakages that cannot be attributed to construction defects.

4.2.5 If the CUBIC pump was shipped with the air outlet silencer disassembled, proceed with assembly.



### **CAUTION: risk of chemical reactions to water**

Before installing the pump for use with liquids that react with tap water, it is necessary to open the product circuit and dry all internal surfaces.

4.2.6 Raise the pump and move it to the place of installation.



**Pump handling is complete.**

## 4.3 POSITIONING AND INSTALLATION



The installation operations are reserved for qualified and authorised Installers, equipped with suitable Personal Protective Equipment (PPE), who know and comply with the contents of this Manual. Since an endless variety of products and chemical compositions exist, the user is presumed to have the best knowledge of their compatibility and reaction with the pump's construction materials. Before using and installing the pump, all necessary checks and tests must be performed with great care to avoid even the slightest risk, an event that the Manufacturer cannot foresee and for which he cannot be held responsible.

### General installation requirements

- Adequate space to allow future maintenance;
- Pump installation with horizontal axis;
- Tightening on rigid supports (to ceiling or floor) with flatness (0.1 mm);
- With negative suction head for fluids with Max density up to 5,000 Cps at 20°C and a Max specific weight of 1.4 Kg/l;
- Installations with positive suction head for fluids with Max density up to 20,000 Cps at 20°C;
- Positioning near the point of collection (max 10 times the suction diameter);
- Suction inlet away from vortices;
- Earthing of the pump for installations in a potentially explosive environment;
- Pneumatic circuit supply with dried, non-lubricated water;
- Installation of an on-off valve, 3-way valve and check valve on the air supply.

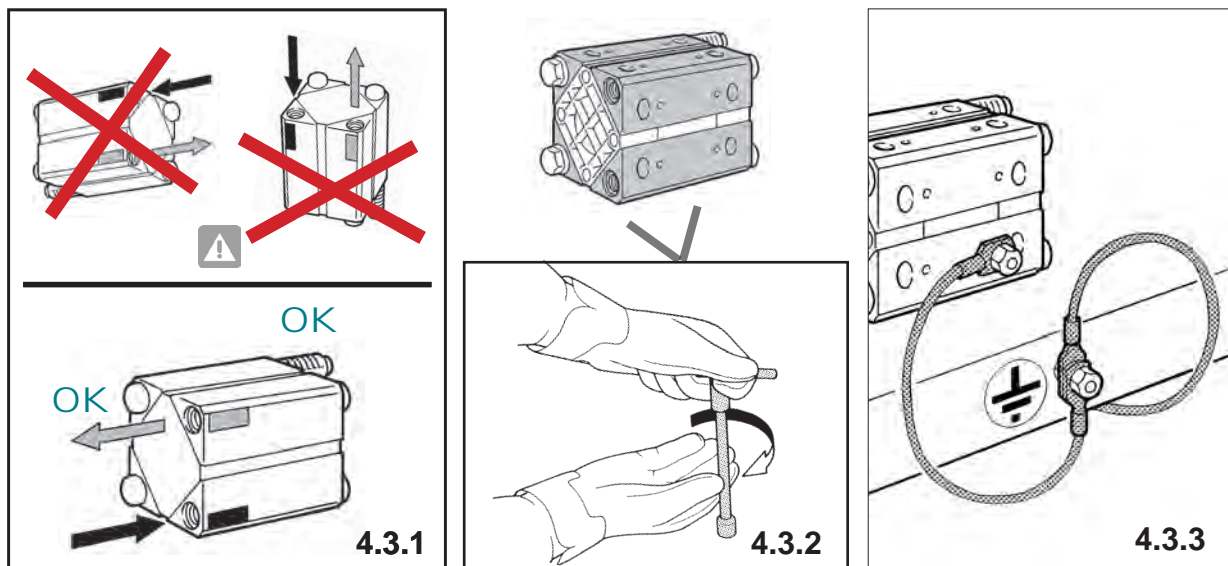

- 4.3.1 Position the pump with the horizontal axis at the place of installation, as close as possible to the point of collection, aligning it with the suction and delivery ducts.



#### NOTE

The product delivery manifold must always be positioned in the upper area:

- 4.3.2 Bracket on rigid supports (ceiling or floor with suitable flatness 0.1 mm) with appropriate washers and screws.
- 4.3.3 If the pump is made of conductive material (CONDUCT execution) and suitable for pumping permitted flammable fluids, it is necessary to install a suitable earthing cable on each pump casing; **danger of explosion and/or fire due to electrostatic currents.**



#### CAUTION: danger of explosion

The pump must always be earthed, regardless of other organs connected to it. Failure or incorrect earthing will cancel the requirements for safety and protection from danger of explosion.

**Pump positioning is thus completed.**

#### 4.3.4 PRODUCT CIRCUIT CONNECTION

After positioning, it is possible to connect the pump to the product circuit as follows:



##### **CAUTION: risk of chemical reactions with water**

Before installing the pump for use with liquids that react with tap water, it is necessary to open the product circuit and dry all internal surfaces.

##### Product system piping requirements

- The connection fittings must be made of the same material as the pump with cylindrical threads (do not use tapered threads);
- Pump connection must include a piece of flexible hose with a metal core (do not attach the pump directly with rigid pipe);
- all flexible hoses present must be reinforced with a metal core;
- Piping must be self-supported and must not burden on the pump;
- Correct sizing of the ducts (suction and delivery) for correct suction speed;
- Product on/off valves (suction and delivery, that do not cause pressure drops);
- With suspended particulate, install a correctly sized strainer on the suction (surface 2.5 / 3 times the suction section of the pump with maximum allowed slot);
- With products that crystallise, provide a washing a circuit (with compatible products);
- Product ducts clean inside and without solid processing residues (shavings, particulates, etc.).

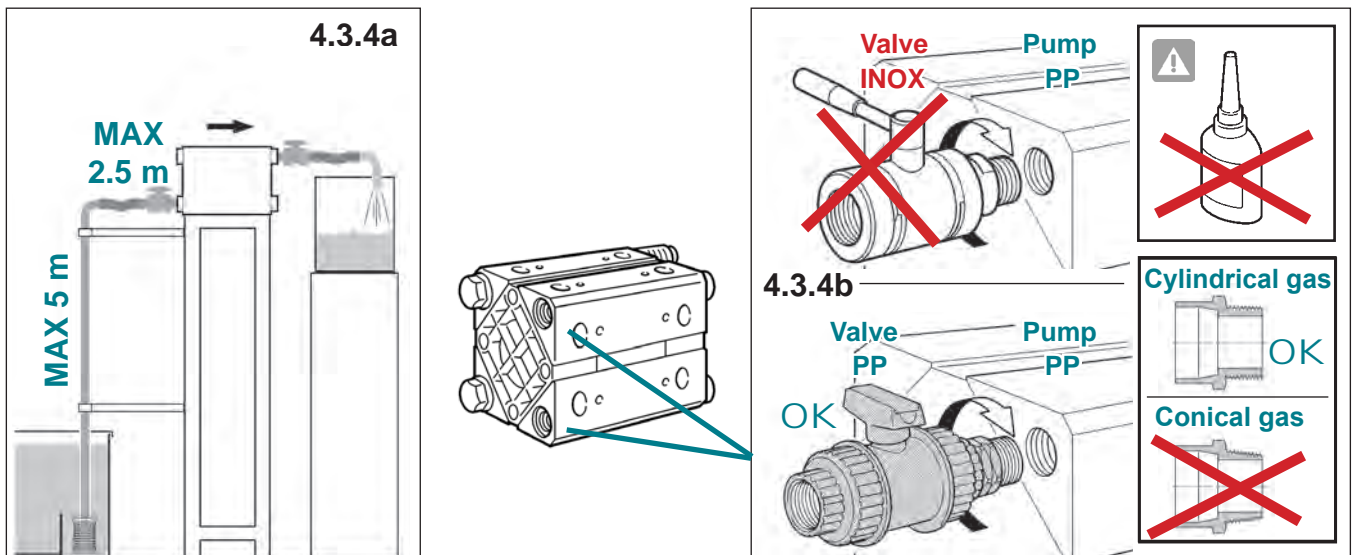

4.3.4a Diaphragm pumps with negative suction are affected by the following factors:

**- fluid viscosity - specific fluid weight - diameter - length and/or bends on the suction.**

Position the pump as close as possible to the point of collection (within 2.5 m) and, in all cases, never higher than 5 m vertically. The suction pipe diameter must never be smaller than that of the pump connection; it must be suitably sized as the distance or viscosity of the fluid increases.



##### **CAUTION: risk of premature wear and/or diaphragm rupture.**

The fluid to be pumped with negative suction must never exceed a viscosity of 5,000 Cps at 20°C and a specific weight of 1.4 Kg/l.

**With higher viscosities, physical factors intervene that require a correct evaluation; therefore, it is always necessary to contact the Manufacturer's Technical Department in advance.**

4.3.4b CUBIC series pumps are supplied with the product connection seats with Cylindrical gas threads. For connections to the pump manifolds, only use fittings with cylindrical gas threads (non-tampered) of the same material as the pump.

**Example: (PP pump = PP fittings) or (INOX pump = INOX fittings).**

On the delivery and discharge manifold install a manual valve of the same diameter as the pump inlet (never smaller) or larger for negative suction or for fluids with high viscosity.

If necessary, load two turns of PTFE tape on the thread and tighten the valves onto the pump manifolds (with moderate clamping pressure) until the seal is ensured.



**CAUTION: risk of breakage and/or failures of the threads.**  
Do not use thread lockers and/or Teflon paste and conical threads. Excess PTFE tape and/or excessive clamping pressure can cause cracks on the manifolds and/or failure of the threads.

4.3.4c In case of a vertical product delivery higher than 5 meters, it is necessary to install a check valve on the system piping, to prevent the fluid from burdening inside the pump.

4.3.4d Install the sleeves to secure the flexible hoses on both valves.

**CAUTION: do not connect the pump DIRECTLY with rigid pipe.**  
In case of negative installations and/or high-viscosity fluids, use hoses with an OVERSIZE DIAMETER, especially on the intake side. The filters or other equipment installed at the intake side must be suitably dimensioned to avoid pressure drops.

4.3.4e Connect the metal-core hose to the suction and product delivery connections, observing the arrows indicated on the pump.

**CAUTION**  
Check that the connection piping to the pump is clean inside and does not contain solid or processing residues.

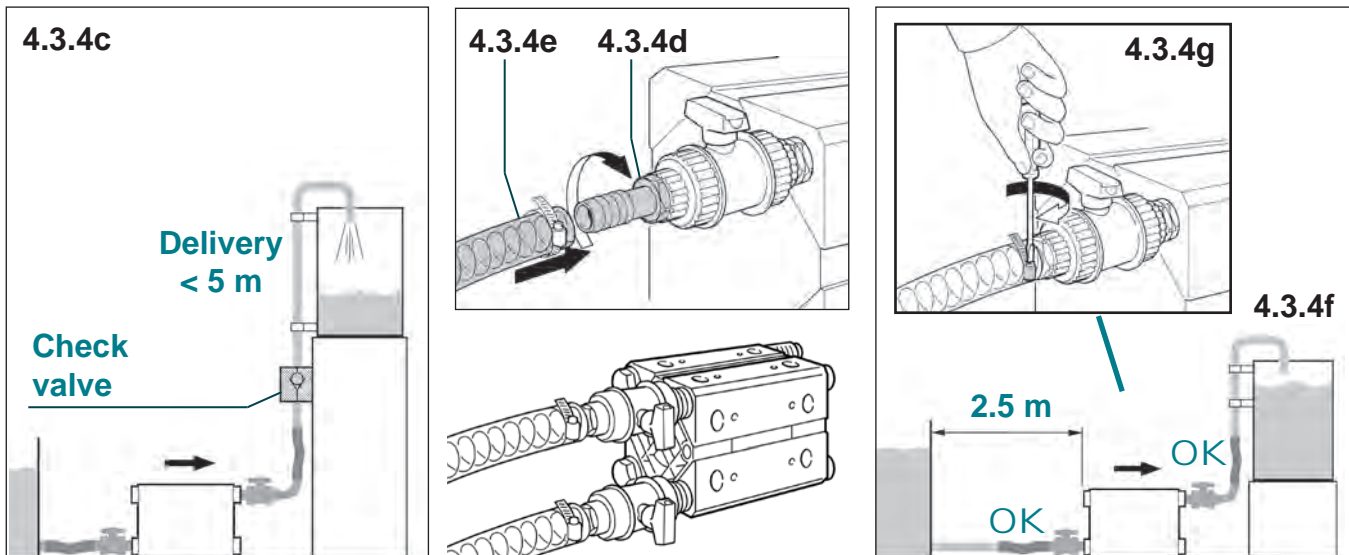

4.3.4f Connect the flexible hoses to the rigid ducts (suction and delivery) of the system.

**CAUTION: danger of stress corrosion cracking.**  
Check that the system ducts are fixed and self-supporting and that they do not burden the pump. Pay particular attention to stress corrosion cracking phenomena. The pump material may deteriorate due to the combined action of corrosion and application of a load, which may cause parts subjected to stress to break suddenly and unexpectedly, especially at low temperatures.  
**The pipes must be strong enough so as not to deform under suction and must never burden the pump and vice versa.**

4.3.4g Fix flexible hoses on the pump and the system with appropriate hose clamps.

**CAUTION: risk of premature wear and/or diaphragm rupture.**  
Apart from the shut-off valve, do not install any other components on the pump suction (couplings, elbows, valves, filters, coiled flexible hoses, etc. - [see diagram on page 33](#)), which could compromise the pump suction performance and cause premature breakage of the diaphragms. **The product on-off valves must always be fully open during operation (never choked).** With high negative heads and/or high viscosity (if necessary), the pump must be pneumatically fed gradually using a “soft start” valve.



4.3.4h If used for drum suction (not positive suction head), the submerged end of the intake hose must be provided with a diagonally cut fixing to prevent it from adhering to the drum bottom.

4.3.4i In installations where the presence of solid particulate is expected, install a suitably oversized strainer (which does not cause pressure drops) on the suction inlet, with a surface area of 2.5 / 3 times the area of the suction pipe and passages smaller than the particulate allowed by the pump model being installed.



**CAUTION: risk of pump damage.**

**It is forbidden to install the pump in the absence of a suitable and correctly sized strainer.**

Check that the treated fluid does not contain any large solid parts or with a harmful shape and that there are no restrictions to the pump inlet or outlet to avoid cavitation and stress to the pneumatic motor and diaphragms.

4.3.4j In installations in a potentially explosive environment which involve the possible presence of solid parts suspended in the fluid, it is essential to install a correctly sized strainer to ensure the pump operates according to the safety requirements set by the relevant marking.

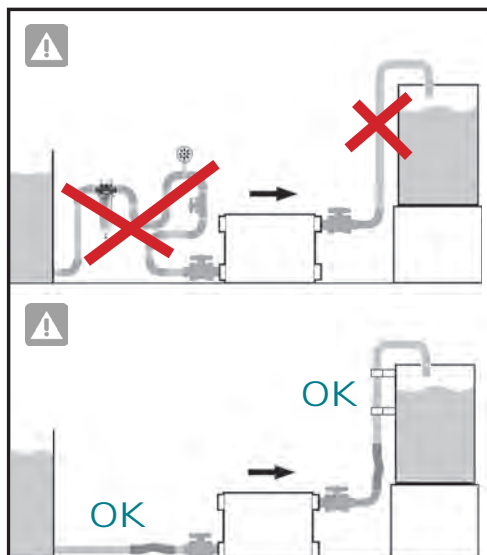

4.3.4h

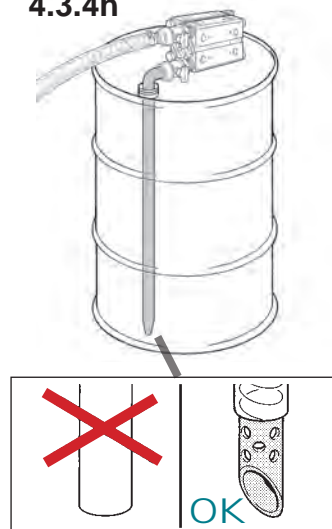

4.3.4i

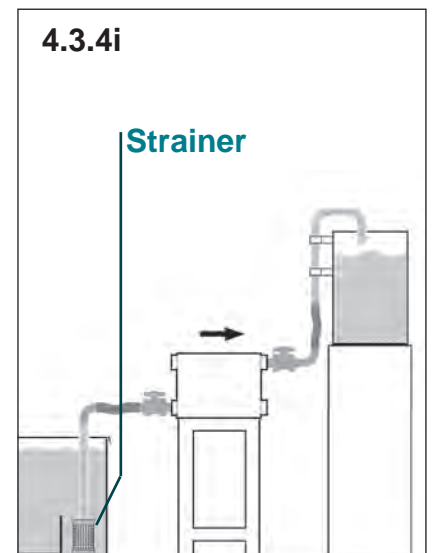

**CAUTION: risk of pump damage and cancelling of the marking requirements**

**It is forbidden to install the pump in the absence of a suitable and correctly sized strainer.**

Provide for periodic checks and maintenance of the installed strainer and of the suction and delivery ducts to maintain and ensure the correct operation of the pump required by the marking for operation in a potentially explosive environment.

**The product circuit connection is thus completed.**

## 4.4 PNEUMATIC CONNECTION



The connection operations to the pneumatic system are reserved for qualified and authorised Installers who know and follow the contents of this Manual and are equipped with suitable Personal Protective Equipment (PPE). After completing the installation, it is possible to connect the pump to the pneumatic supply circuit as follows:

### Pneumatic system requirements

- Supply with non-lubricated, dried air, with suitable pressure (Min 2 bar - Max 8 bar);
- Use of pneumatic components with air flow rates suitable for the pneumatic circuit of the pump;
- Glycol adder for installations with strong delivery heads and/or back-pressures;
- Installation of shut-off valve, 3-way valve, and non-return valve on the air supply;
- Installation of an air discharge pipe (with collection) outside environments with a heavy and potentially explosive atmosphere and for pumping flammable or toxic fluids.

4.4.1 Remove the sticker from the air connection of the pump.



### CAUTION: danger of pump blocking.

The pneumatic supply of the CUBIC series pumps must be performed with UNLUBRICATED, FILTERED AND DRIED compressed air with a pressure of not less than 2 bar and not more than 8 bar.

ONLY for glycol

**NO OIL**

POS.	COMPONENT
1	Air pump
2	Pressure gauge
3	Adjustment valve (SPEED)
4	3-way valve - air discharge (START - STOP)
5	Check valve
6	Soft start valve
7	Filter/Regulator (20µ - micron)
8	3-way valve - interlocking (EMERGENCY)
9	Pressure Relief Valve

4.4.2 Tighten a compressed air flow control valve, a 3-way valve (START - STOP with air discharge) and a check valve on the pneumatic circuit connection of the pump, as per the diagram in the figure. Install a pressure gauge on the compressed air connection of the pump itself and check the value with the pump running to check the actual pressure of the supply air.



### CAUTION: danger of fluid entering the compressed air circuit and being discharged into the environment.

Do not install the pump without the 3-way valve (START - STOP) and/or the check valve to prevent the pumped fluid from entering the pneumatic circuit if the diaphragms break. In battery installations, the check valve must always be installed on each pump.

4.4.3 Install a 3-way EMERGENCY stop valve upstream of the pneumatic supply circuit (disconnecter with interlock) in a protected and easily accessible position.

4.4.4 Installations where operation with many Start/Stop cycles is expected (with high delivery heads and/or with strong back-pressures) require the installation of a pneumatic soft start valve to protect the product diaphragms.



### NOTE

Besides providing a more smooth and fluid pumping of the product during the start-up phase, installing the soft start pneumatic valve protects the diaphragms and preserves the operating life of the pump.



- 4.4.5 Pump installations with high delivery heads and/or strong back-pressures may cause the pneumatic circuit outlets to freeze.



**CAUTION: danger of loss of efficiency and/or pump shutdown.**

With strong heads and/or high viscosity, provide for the installation of a glycol dispenser on the air supply line upstream of the pump.

- 4.4.6 The air of the pump's pneumatic circuit must always be discharged in a free, non-dusty atmosphere and free of saturated vapours that can damage the internal circuit. In the event of a total rupture of the diaphragms, the fluid can enter the pneumatic circuit, damage it and exit from the drain.



**CAUTION: danger of damage to the internal pneumatic circuit.**

For installations with the pump immersed or for operation in environments with a heavy atmosphere (dust, vapours or saturated vapours), it is necessary to install a pipe and fittings (of suitable materials) to bring the air discharge point outside the environment/process liquid.



**CAUTION: risk of fluid leaking in case of breakage of the diaphragms.**

In installations for pumping flammable (allowed by the marking), corrosive, toxic or dangerous fluids, the air discharge must be conveyed in suitable piping to a safe collection area.

- 4.4.7 Connect the compressed air supply pipe to the pump circuit.

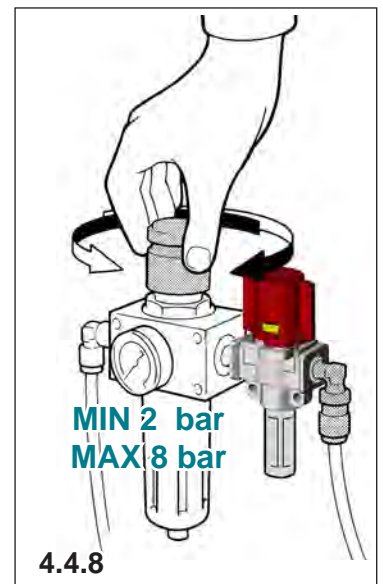
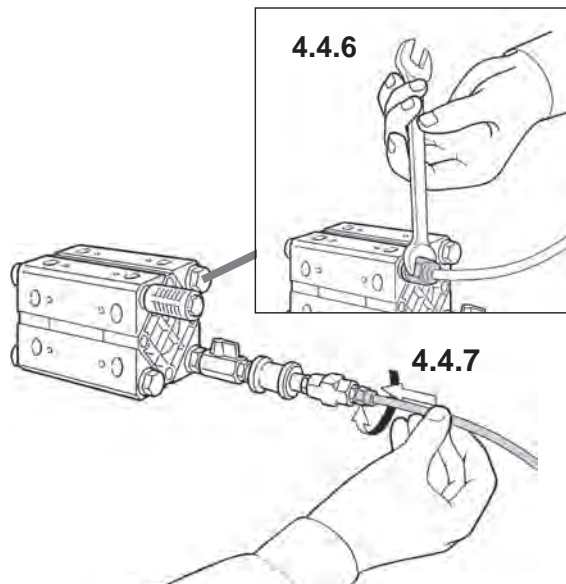
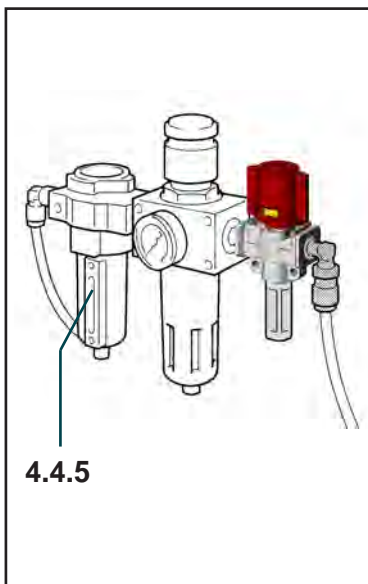

**CAUTION: risk of pneumatic pressure drop.**

Use pipes, accessories and control and regulation elements with flow and pressure characteristics suitable for the characteristics of the pump in order not to cause pressure drops. **Pay attention to snap-on fittings: most of them cause pressure drops.**

- 4.4.8 Adjust the network pressure of the compressed air to guarantee pressures of not less than 2 bars and not more than 8 bars when the pump is running.



**CAUTION: risk of stalling and/or diaphragm rupture.**

To feed more than one pump with the same air control device, contact the DEBEM Technicians. Lower or higher pressures may cause functional problems or pump breakage, product spills and damages to persons and/or objects.

- 4.4.9 **FOR INSTALLATIONS IN ZONE 1 - ZONE 21**

Should the user think that there is a risk of exceeding the temperature limits set forth in the marking affixed to the pump for use in a potentially explosive classified ZONE, a protective device must be installed on the system to prevent the global temperature (fluid + ambient) from being reached as indicated in [Section "2.7 TECHNICAL FEATURES"](#).

**⚠ ATTENTION: danger of loss of the affixed ATEX marking.**  
It is forbidden to use the pump at temperatures higher than those permitted and specified in the manual; **if the maximum temperature is exceeded, the conformity of the ATEX marking will be invalidated.**

- 4.4.10 If the pump (for the CUBIC model only) is equipped with the COUNTER device (to detect and/or display the number of cycles of the pump), make the electrical connection.
- 4.4.11 Always protect the pump from possible accidental blows and contact with incompatible fluids that can damage and/or react upon contact with it.
- 4.4.12 If the pump is used with flammable, aggressive, toxic or harmful fluids for health and/or in installations in zone 1 - zone 21 with flammable fluids (allowed by the marking), it is necessary to install an adequate protection (for containment, collection and outflow of the product in a safe area), and a buzzer in case of spillage.

**⚠ CAUTION: danger of pollution, contamination, injuries or, in extreme cases, death.**  
It is forbidden to install the pump in the absence of a suitable protection for containment with a collection tank and outflow in a safe area of flammable, aggressive or toxic liquids or with liquids that may represent a health hazard.

The pneumatic circuit connection and the pump installation are thus completed.

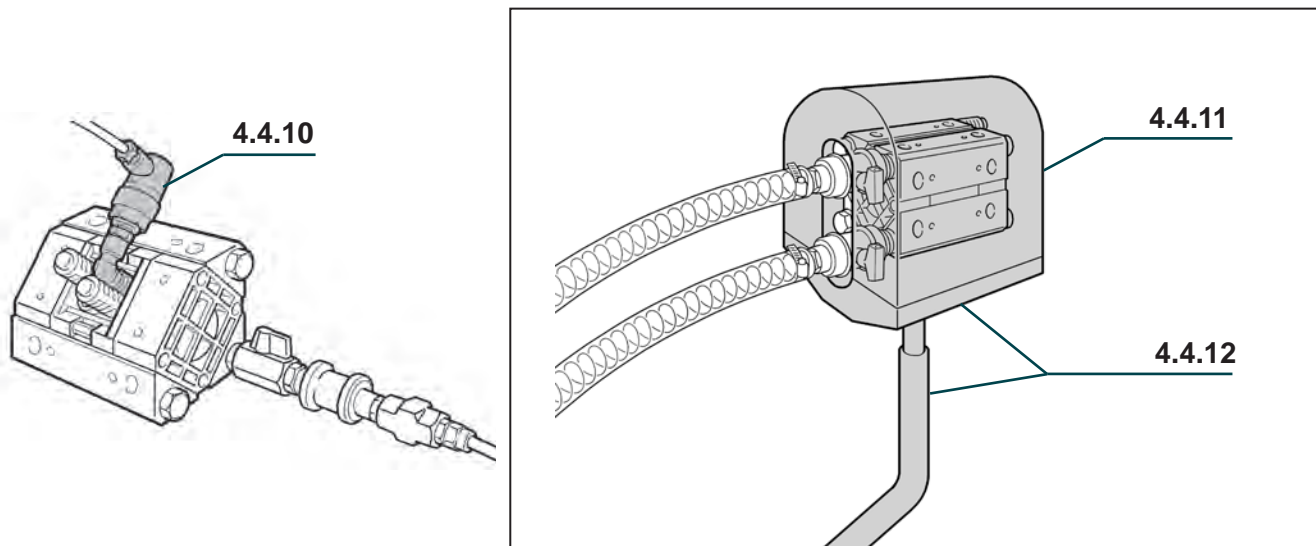

## 4.5 CHECKS BEFORE COMMISSIONING



Depending on the type of application, the type of fluid used, and the installation/work environment, it is necessary to affix appropriate indications and indicate the residual risk present near the pump.



Before commissioning the pump, to verify that the installation meets the intended operating conditions, it is essential to carry out the following checks with the pump running:

- 4.5.1 With a pressure gauge positioned directly on the air inlet of the pump (downstream of all devices and fittings installed on the supply line), check that the detected pressure does not have any pressure drops compared to the reading on the pressure gauge of the filter of the pneumatic network supply line.
- 4.5.2 With a pressure gauge directly on the pump delivery manifold, check that the actual pressure of the pumped fluid at the pump outlet is correct compared to the Technical data of the installed Model.

The pump is ready for commissioning.



The topics in this chapter are divided into sections, taking into account the operational phases for commissioning, operation and stop methods.

THIS PART INCLUDES THE FOLLOWING TITLES		PAGE
<b>5.1</b>	<b>COMMISSIONING AND OPERATION</b>	<b>38 - 39</b>
<b>5.2</b>	<b>NORMAL SHUTDOWN OF THE PUMP</b>	<b>40</b>
<b>5.3</b>	<b>EMERGENCY STOP OF THE PUMP</b>	<b>41</b>

Below is a description of how to behave in each of the phases listed above.

## 5.1 COMMISSIONING AND OPERATION



The start-up and commissioning of the pump are reserved for trained and authorised Installers who know and follow the Original Instructions.

The user must always use fluids that are compatible with the original design conditions of the pump itself and the ATEX marking affixed.



**CAUTION: risk of damaging the pump and product leakage and/or explosion.**

It is forbidden to use the pump with fluids that are not compatible with the construction materials of the components or in an environment with the presence of incompatible fluids and atmosphere.

Proceed as follows to commission the pump:

### Pump start-up requirements

- Presence of fluid in the collection tank;
- Pump fluid compatible with chemical and temperature characteristics of the pump materials and the affixed ATEX marking;
- Suction and delivery circuit running and no maintenance on the system;

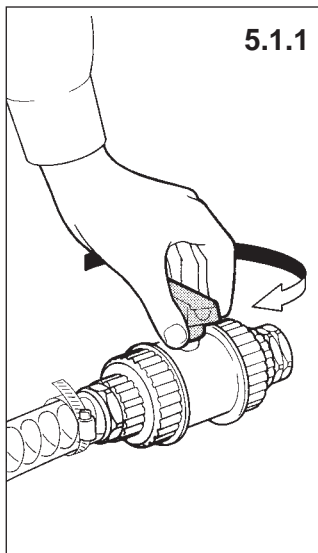

5.1.1

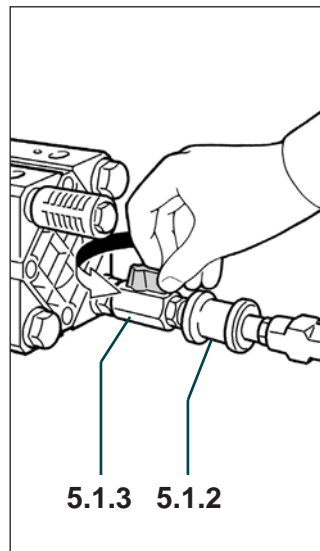
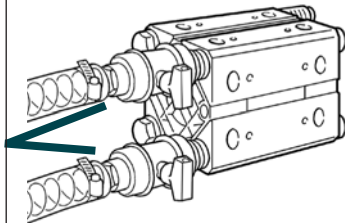

5.1.3 5.1.2

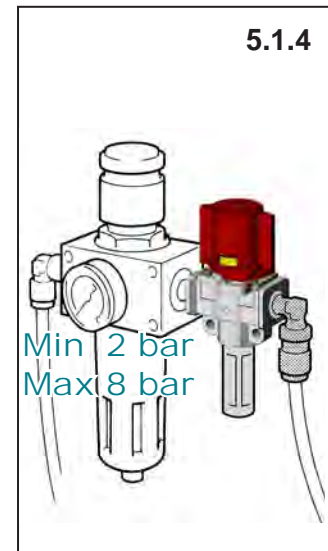

5.1.4

- 5.1.1 Open the product sectioning valves of the suction and delivery pipes.



**CAUTION: risk of premature wear and/or diaphragm rupture.**

It is forbidden to start the pump with the product valves (suction and delivery) closed or choked.

- 5.1.2 Open the 3-way pneumatic valve on the pump.

- 5.1.3 Gradually open the compressed air control valve mounted on the pump connection; the pump will start running.

- 5.1.4 Check and adjust accordingly the air pressure on the network (with the pump running): MIN 2 bar MAX 8 bar.



**CAUTION risk of stalling and/or premature wear and/or diaphragm rupture.**

The pump may STALL with pressures below 2 bar (with the pump running). With pressures higher than the MAXIMUM threshold (Max 8 bar), failures, pressurised product leakage and/or pump breakage may occur.

5.1.5 If an adjustment of the pump speed is required according to the viscosity of the fluid to be pumped, it is possible to operate in two different ways:

5.1.5a Adjust the network air supply pressure;

5.1.5b Choke the air volume (flow rate) using the air control valve on the pump.



**CAUTION: risk of premature wear and/or diaphragm rupture.**

Do not close or operate on the product suction valve to choke the fluid.

5.1.6 Check that there is no abnormal noise during operation and that “gas” is not present in the outlet fluid; the presence of vortices on the suction point results in cavitation and malfunctions.

Besides being damaging for the pump, cavitation is particularly dangerous in a potentially explosive atmosphere: it is necessary to check that the pump has been correctly sized; **if in doubt, do not hesitate to contact the DEBEM Technicians.**



**CAUTION: risk of damaging the pump and/or premature wear/diaphragm rupture.**

Abnormal noise or the presence of “gas” in the fluid exiting from the pump indicate an abnormal condition for which it is always necessary to determine the cause before continuing; **in such cases, immediately stop the pump and resolve the anomalous conditions before continuing.**

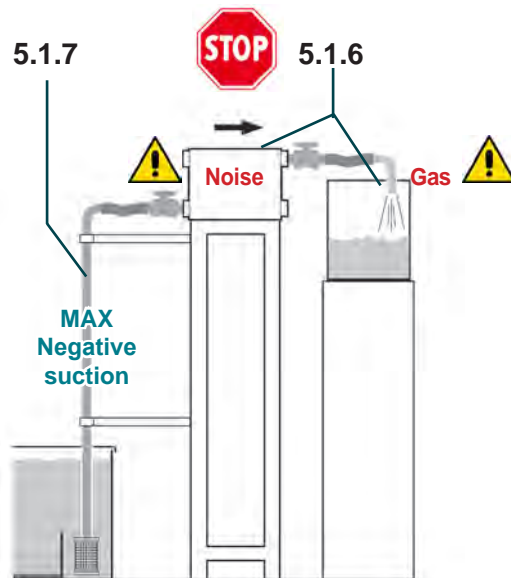
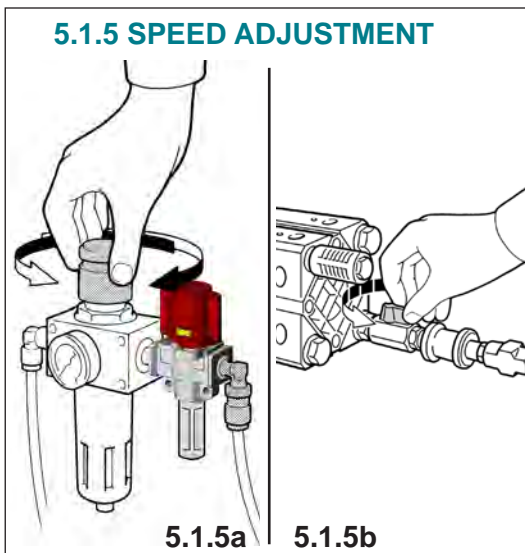

5.1.8

Il livello di prestazioni delle pompe serie CUBIC si riferisce alle condizioni standard: 1 metro di Pendenza MAX (max Head) di progetto a 20°C, con un tubo di aspirazione immerso con profondità di 0,5 m con un tubo di 1" e velocità di 10 m/min. Capacità di movimento sono riportate con riferimento a queste condizioni.

NOTA: In caso di aspirazione negativa e sotto depressione si riferire al paragrafo di fluidi con viscosità e peso specifico oltre 1,1 e ricorrere a un tubo di aspirazione con diametro superiore ai requisiti indicati.

- velocità a pieno carico del tubo;
- tubazione a diametro doppio di aspirazione con presenza di curve in aspirazione sul circuito prodotto.

ASPIRAZIONE NEGATIVA con fluidi fino a 0,500 cpa a 20°C ed un peso specifico massimo di 1,4 Kg/l

ASPIRAZIONE SOTTO VUOTO con fluidi fino a 0,200 cpa a 20°C e un peso specifico massimo di 1,4 Kg/l

Capacità massima di aspirazione (max Head) con tubi di aspirazione con diametro 1" e profondità di immersione di 0,5 m.

Nota: questi dati di progetto vengono forniti solo per i modelli di riferimento. Per ulteriori informazioni, consultare le schede tecniche dei vari modelli.

MODELLO	DEBITO	INTELLIGIBILITÀ	CUBICITÀ
CP100	100	100	100
CP150	150	150	150
CP200	200	200	200
CP250	250	250	250
CP300	300	300	300
CP350	350	350	350
CP400	400	400	400
CP450	450	450	450
CP500	500	500	500
CP550	550	550	550
CP600	600	600	600
CP650	650	650	650
CP700	700	700	700
CP750	750	750	750
CP800	800	800	800
CP850	850	850	850
CP900	900	900	900
CP950	950	950	950
CP1000	1000	1000	1000

5.1.7 If the installed pump has negative suction or is used with highly viscous fluid, reduce the pump speed by acting on the air control valve. Non-primed pumps have a negative suction capacity that varies according to the type of diaphragm and packing mounted; **CONTACT THE MANUFACTURER’S CUSTOMER ASSISTANCE SERVICE FOR FURTHER DETAILS.**



**CAUTION**

For pumps with split manifolds, do not use fluids with different viscosities; **standstill, early diaphragm and pneumatic circuit wear/breakage may occur.**

5.1.8 The diaphragms, (internal and in contact with the product) are components subject to wear. Their duration is strongly affected by the conditions of use and by the chemical and physical stresses. From tests carried out on thousands of installed pumps (with head equal to 0.5 m at 20°C), it was found that the normal duration exceeds 100,000,000 (one hundred million) cycles.



**CAUTION**

For safety reasons, in environments with a potentially explosive atmosphere and for pumping flammable fluids (admitted by the marking), the pump diaphragms must be disassembled and checked every 10,000,000 (ten million) cycles and replaced every 20,000,000 (twenty million) cycles.



**Perform the maintenance and replacements provided for by the Manufacturer on a regular basis.**

## 5.2 NORMAL SHUTDOWN OF THE PUMP



Do not stop pumping the liquid and/or the operating pump by closing the on/off valves of the product suction and/or delivery duct. The pump and the fluid must always be stopped by switching off the pump pneumatic motor by disconnecting the air.

### Requirements after the normal shutdown of the pump

- After the normal shutdown of the pump, the liquids that crystallise must be discharged, and the inside of the pump must be washed immediately after stopping;
- If the liquid to be processed is changed after the pump has stopped, it is necessary to perform draining and internal washing;
- After the pump has shut down, it is necessary to drain the toxic or harmful liquids and perform internal washing before performing repair or maintenance operations.

- 5.2.1 Only act on the air supply to shut down the pump normally: close the control valve, the 3-way valve **and discharge the residual pressure of the pump pneumatic system.**



### **CAUTION** risk of stall, premature wear/rupture of the diaphragms.

Never stop the pump (when it is running and/or when the pneumatic circuit is under pressure) by closing the product circuit suction valves to avoid premature wear and/or breakage of the diaphragms and residual pressures in the pneumatic circuit inside the pump.

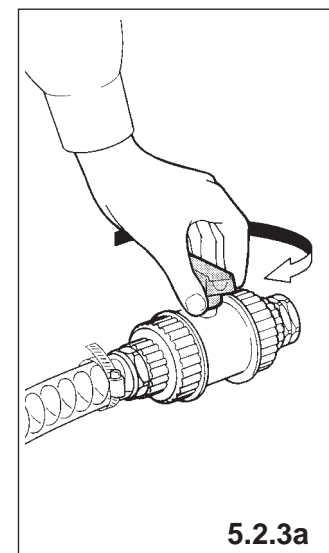
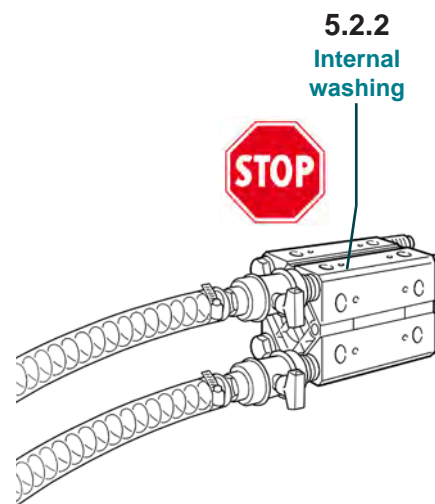
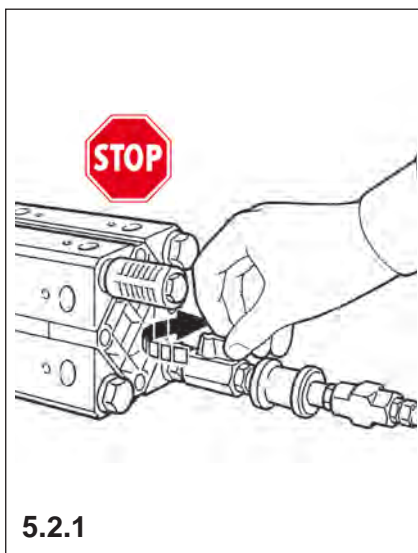

- 5.2.2 The CUBIC series pumps are not self-draining, so if they are used with crystallising fluids, it is always necessary to flush them internally with a suitable liquid immediately after stopping.



### **CAUTION: risk of damaging the pump.**

The prolonged shutdown of the pump containing fluids that crystallise can cause the valves and diaphragms to stick and the subsequent malfunction.

- 5.2.3 If the shutdown is definitive and prolonged, it is necessary to:

- 5.2.3a If necessary, the product valves can only be closed after stopping the pump pneumatically.

- 5.2.4 After the first two hours of operation and after stopping the pump correctly, check that all of the pump bolts are tight.



### **CAUTION: risk of internal back-pressures and projection of components during disassembly.**

In abnormal conditions (incorrect installation and/or shutdown and/or standstill conditions), residual pressure, which is not relieved, may be generated inside the pump. Before opening and disassembling the pump, it is necessary to secure the pump casings with a suitable ratchet strap and wear suitable Personal Protective Equipment (PPE).

**Pump shutdown has thus been completed.**





## 5.3 EMERGENCY STOP OF THE PUMP



In conditions of detected danger and/or malfunction of the pump, it is necessary to promptly stop it in emergency conditions proceeding as follows.

### Requirements after the pump shutdown

- After an emergency stop, definitively resolve the dangerous situation before restarting the pump;
- After the shutdown of the pump, crystallising liquids must be drained and the pump immediately flushed internally;
- If the liquid to be processed is changed after the pump has stopped, it is necessary to perform draining and internal washing;
- After the pump has shut down, it is necessary to drain the toxic or harmful liquids and perform internal washing before performing repair or maintenance operations.

- 5.3.1 To stop the pump in emergency conditions, act only on the compressed air supply. Readily operate on the 3-way sectioning valve (from a protected position upstream of the supply circuit) for the EMERGENCY stop command.

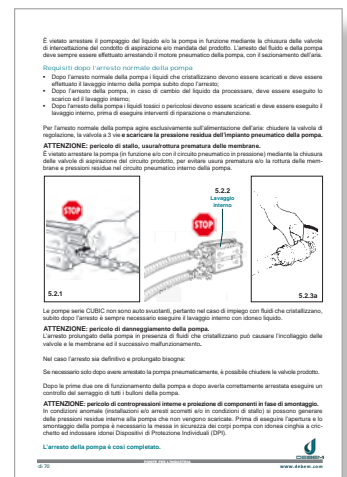
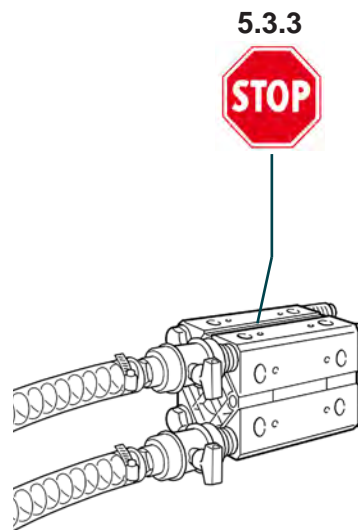
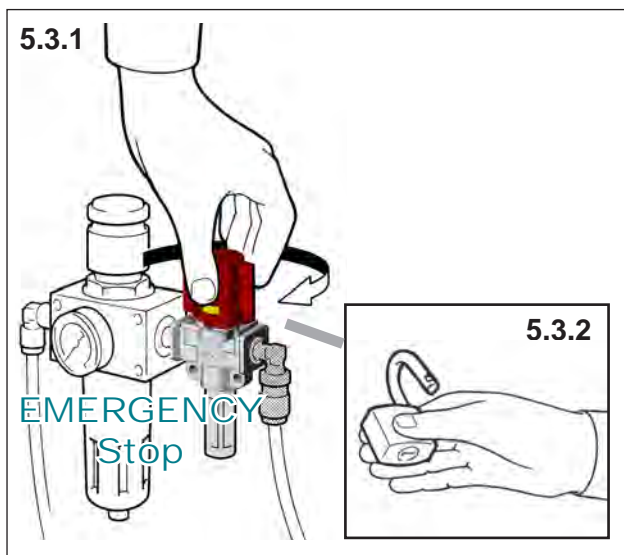

5.3.4



### CAUTION: risk of stall, premature wear/rupture of the diaphragms.

Never stop the pump (when it is running and/or when the pneumatic circuit is under pressure) by closing the product circuit suction valves to avoid premature wear and/or breakage of the diaphragms and residual pressures in the pneumatic circuit inside the pump.

- 5.3.2 Interlock the 3-way safety valve of the compressed air supply before operating.
- 5.3.3 Resolve the hazardous condition permanently before restoring the compressed air supply to the pump.
- 5.3.4 If the stop is prolonged and/or permanent, proceed as described in *Section 5.2 NORMAL SHUTDOWN OF THE PUMP*.

Pump emergency stop has thus completed.

## CHAPTER 6

This chapter contains the maintenance timetable or the operations foreseen by the Manufacturer to ensure safe and long-lasting maintenance of the CUBIC series pumps.

THIS PART INCLUDES THE FOLLOWING TITLES		PAGE
6.1	SCHEDULED MAINTENANCE TABLE	43
6.2	EXTERNAL CLEANING AND TIGHTNESS CHECK	44 - 45
6.3	TIGHTNESS CHECK	46 - 47
6.4	PRODUCT CIRCUIT MAINTENANCE	48 - 52
6.5	AIR CIRCUIT MAINTENANCE	53 - 55

Below is a description of how to behave in each of the phases listed above.

## 6.1 SCHEDULED MAINTENANCE TABLE



The scheduled maintenance operations are reserved for qualified and authorised Mechanical Servicemen, equipped with suitable Personal Protective Equipment (PPE), who know and comply with the contents of this Manual.

To ensure optimal performance and safe use of the pump, it is necessary to periodically perform the routine maintenance operations indicated in the following table and dealt with in the following sections.

The timing of the reported operations refers to use under normal conditions; for harsh installations and operating conditions, the indicated ranges must be adjusted accordingly.

SEC.	SCHEDULED MAINTENANCE	every 500 hours	500,000 cycles	10,000,000 cycles	20,000,000 cycles
<b>6.2</b>	<b>EXTERNAL CLEANING AND TIGHTNESS CHECK:</b>		check	check	replacement
6.2.1	• External cleaning of the Pump	✓	--	--	--
6.2.2	• Product circuit tightness check	✓	--	--	--
<b>6.3</b>	<b>TIGHTNESS CHECK</b>		check	check	replacement
6.3.1	• Tightness check	--	✓	--	--
6.3.2	• Tightening torque table	--	--	--	--
<b>6.4</b>	<b>PRODUCT CIRCUIT MAINTENANCE:</b>			check	replacement
6.4.1	• Pump Disassembly	--	--	✓	✓
6.4.2	• Internal cleaning of the product circuit	--	--	✓	✓
6.4.3	• Check and/or replacement of valves	--	--	✓	✓
6.4.4	• Check and/or replacement of diaphragms	--	--	✓	✓
6.4.5	• Pump Re-assembly	--	--	✓	✓
<b>6.5</b>	<b>AIR CIRCUIT MAINTENANCE</b>				
6.5.1	• Pump Disassembly		When necessary		
6.5.2	• Coaxial exchanger replacement		50,000,000 cycles		
6.5.3	• Pump Re-assembly		When necessary		



### CAUTION

In the case of heavy uses (concentrated corrosive liquids or liquids that crystallise), it is necessary to increase the frequency of operations.



### CAUTION: risk of internal back-pressures and projection of components during disassembly.

In abnormal conditions (incorrect installation and/or shutdown and/or standstill conditions), residual pressure, which is not relieved, may be generated inside the pump. Before opening and disassembling the pump, it is necessary to secure the pump casings with a suitable ratchet strap and wear suitable Personal Protective Equipment (PPE).

## 6.2 EXTERNAL CLEANING AND TIGHTNESS CHECK



This operation is reserved for trained and qualified maintenance technicians equipped with appropriate Personal Protective Equipment (PPE) (see *Technical and Safety Data Sheets* of the liquid treated).



### CAUTION: risk of contact with toxic or corrosive fluids.

The external cleaning and tightness check of the suction and delivery circuit of the pump must be carried out periodically following the procedures described below.

### 6.2.1 EXTERNAL CLEANING OF THE PUMP

The pump must be cleaned externally periodically every 500 hours of operation to allow visual inspections and safe operations. The presence of dust and/or deposits on the external surfaces of the pump can negatively affect process temperatures. In environments with a potentially explosive atmosphere, it can even compromise the safety envisaged by the marking.



### WARNING: danger of overheating and in potentially explosive atmospheres, fire/explosion hazard.

In environments with a potentially explosive atmosphere, it can even compromise the safety, causing overheating and/or flammability of the dust.



6.2.1a



6.2.1c

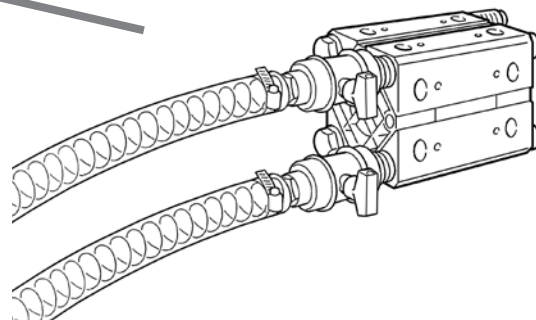

#### Safety requirements before starting the operation:

- Pump shut down with air supply disconnected and interlocked and residual pressure discharged;
- Closed suction and delivery valves;
- Pump and suction and delivery circuits cooled.

Proceed as follows to clean the outside of the pump:

- 6.2.1a Remove dust deposits from the external surfaces of the pump using a disposable cloth dampened with a suitable neutral detergent.



### CAUTION: risk of damage and/or fire.

Do not use detergents that are not compatible with the construction materials of the pump, solvents or flammable substances.

- 6.2.1b Remove dust deposits from the external surfaces of the suction and delivery pipes near the pump using disposable cloths dampened with a suitable detergent (compatible with the construction materials of the pump).

- 6.2.1c Check that the residual risk warning labels are clearly visible and legible; otherwise, replace them. Remove any tools and cloths used from the pump.

#### The external cleaning of the pump is completed.



## 6.2.2 PRODUCT CIRCUIT TIGHTNESS CHECK

The seal of the product circuit of the pump must be checked after the first 2 hours of operation and then periodically every 500 hours, working as follows:



**CAUTION: risk of contact with toxic or corrosive fluids and/or ejection of pressurised fluid.**

Before operating near the pump, it is necessary to wear suitable Personal Protective Equipment (PPE); (see the *Technical and Safety Data Sheets of the treated liquid*).

Safety requirements for the tightness check:

- Pump shut down with air supply disconnected and interlocked and residual pressure discharged;
- Pump with the external surfaces clean;
- Open product sectioning valves (suction and delivery);
- Overflown pump.

### SUCTION SEAL CHECK

The suction seal of the pump must be checked with the pump running, operating as follows:

- 6.2.2a Visually check for leaks on the suction circuit and the pump;
- 6.2.2b If leaks are detected, immediately stop the pump, disconnect the air supply and discharge the residual pressure from the internal pneumatic circuit.
- 6.2.2c If leaks are detected, check the tightening of the fastening parts that are part of the suction circuit (hose connection, clamps, fittings) and/or the screws of the pump casing and manifold.

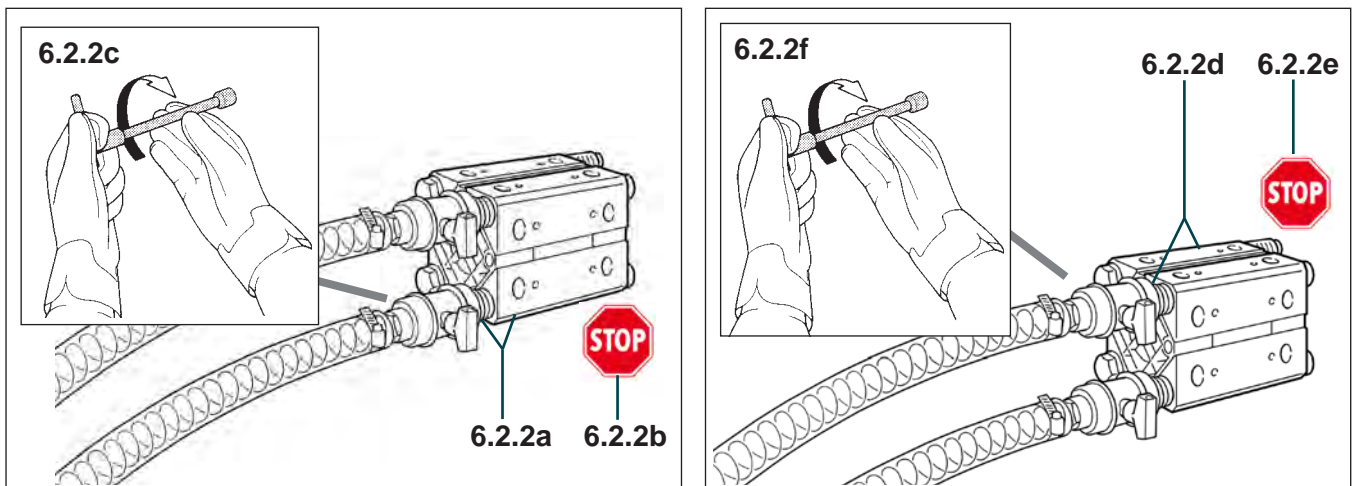

**CAUTION: risk of product leakage.**

The tightness check ensures a correct seal of the product circuit; in the event of leaks or product leaks, it is always necessary to carefully check that the pump and the internal sealing components are intact before commissioning.

**The check of the hydraulic seal of the product suction circuit is completed.**

### CHECKING THE DELIVERY TIGHTNESS

The pressure check must be carried out with the pump running, as follows:

- 6.2.2d Visually check for leaks on the delivery circuit and the pump.
- 6.2.2e If leaks are detected, immediately stop the pump, disconnect the air supply and discharge the residual pressure from the internal pneumatic circuit.
- 6.2.2f Tighten the parts concerned on the delivery line (pipe connection, clamps, fittings) and/or the screws of the pump body and manifold as described in [Section 6.3 TIGHTNESS CHECK](#).



**CAUTION: risk of product leakage.**

The tightness check ensures a correct seal of the product circuit; in the event of leaks or product leaks, it is always necessary to carefully check that the pump and the internal sealing components are intact before commissioning.

**The check of the hydraulic tightness of the product delivery circuit is completed.**



## 6.3 TIGHTNESS CHECK



This operation is reserved for trained and qualified maintenance technicians equipped with appropriate Personal Protective Equipment (PPE) (see *Technical and Safety Data Sheets* of the liquid treated).



**CAUTION: risk of contact with toxic or corrosive fluids.**

### 6.3.1 TIGHTNESS CHECK

The tightness of the pump and product ducts must be checked after the first 2 hours of operation and then periodically every 500,000 cycles.



**CAUTION: risk of product leakage.**

The tightness check ensures a correct seal of the product circuit; in the event of leaks or product leaks, it is always necessary to carefully check that the pump and the internal sealing components are intact before commissioning.

**Safety requirements for the operation:**

- Pump shut down with air supply disconnected and interlocked and residual pressure discharged;
- Closed suction and delivery valves;
- Pump with the external parts cleaned/washed;
- Pump and suction and delivery circuits at MAX ambient temperature 40°C.

Proceed as follows to check the tightness of the pump:

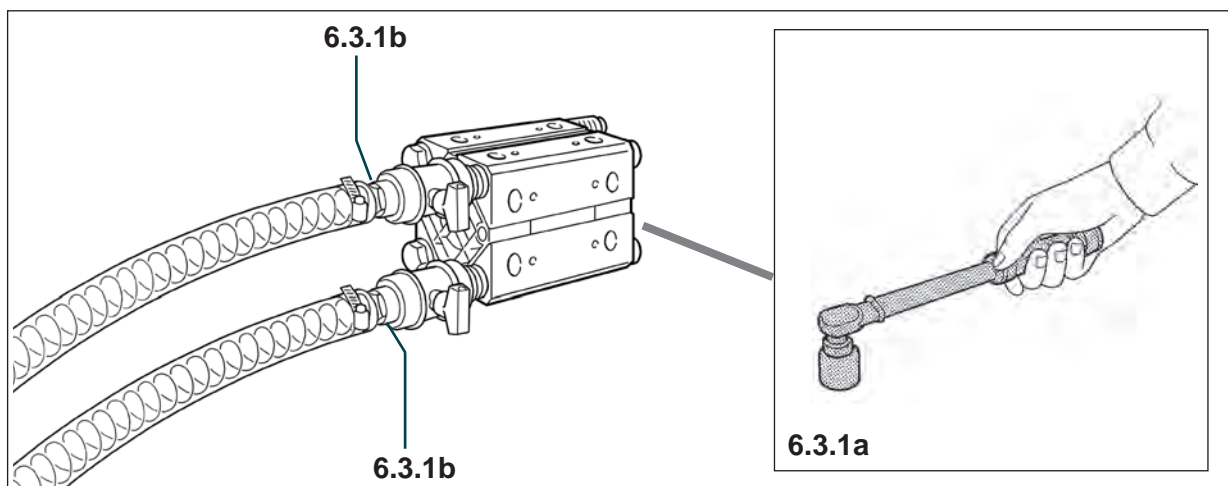

- 6.3.1a Using a suitable torque spanner, check the tightening of the pump screws following the torques indicated in the *TIGHTENING TABLE* on page 47.



**CAUTION: risk of stress corrosion cracking phenomena and sudden breakages.**

Excessive tightening (especially on plastic pumps) can cause dangerous tensions on some components and sudden breakages that cannot be attributed to construction defects.

- 6.3.1b Check the tightness of the connection fittings to the pump and the tightness of the hose clamps of the product ducts.
- 6.3.1c Remove the tools used from the pump.

**The tightness check of the pump and product ducts is completed.**

### 6.3.2 TIGHTENING TORQUE TABLE

The following table shows the tightening torques referred to the construction components and their materials.

Tightening must be carried out respecting the tightening torques indicated by the Manufacturer and expressed in Nm (newton meter), with reference to each model and construction material.



**CAUTION: risk of stress corrosion cracking phenomena and sudden breakages.**

Excessive tightening (especially on plastic pumps) can cause dangerous tensions on some components and sudden breakages that cannot be attributed to construction defects.

PUMP	Material	PUMP BODY	MANIFOLD	CAP	PLUG
MIDGETBOX	PP	4 Nm	--	15 Nm	--
	PP + CF	4 Nm	--	15 Nm	--
CUBIC 15	PP	4 Nm	4 Nm	15 Nm	8 Nm
	ECTFE	4 Nm	4 Nm	15 Nm	8 Nm
	PP + CF	4 Nm	4 Nm	15 Nm	8 Nm

## 6.4 PRODUCT CIRCUIT MAINTENANCE



This operation is reserved for trained and qualified maintenance technicians equipped with appropriate Personal Protective Equipment (PPE) (see *Technical and Safety Data Sheets* of the liquid treated).



### CAUTION: risk of contact with toxic or corrosive fluids.

Maintenance of the pump's product circuit must be carried out periodically to ensure optimum performance and the necessary safety conditions, as described below:

#### 6.4.1 PUMP DISASSEMBLY

To carry out the product circuit maintenance, it is necessary to disassemble the pump as follows:

##### Safety requirements for the operation:

- Pump shut down with air supply disconnected and interlocked and residual pressure discharged;
- Pump with the external parts cleaned/washed;
- Pump with internal product circuit washed and decontaminated (according to the pumped liquid);
- Pump with product circuit drained of the contaminated washing liquid;
- Closed product sectioning valves (suction and delivery);
- Pump and suction and delivery circuits at ambient temperature.

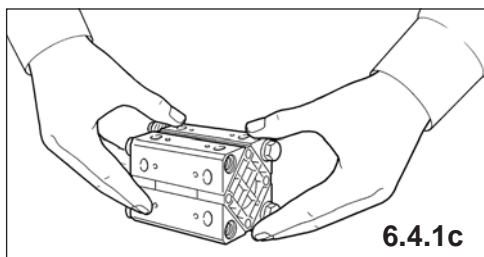

6.4.1c

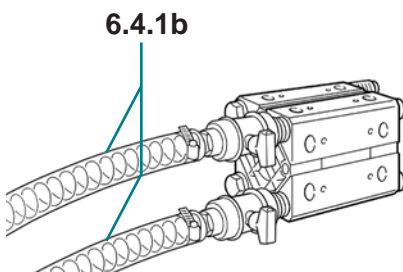

6.4.1b

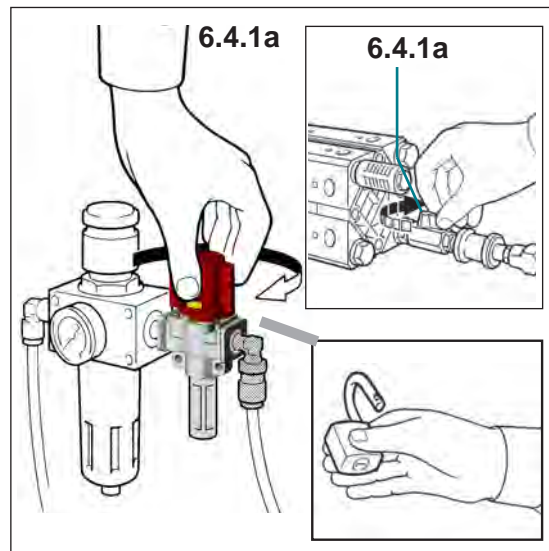

6.4.1a

6.4.1a

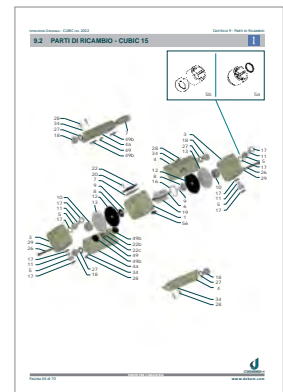

6.4.1d

- 6.4.1a To shut down the pump, only operate on the air supply: close the ball valve and the 3-way sectioning valve. Close the upstream 3-way safety valve, **discharge the residual pressure from the pneumatic system of the pump and place the safety interlock.**



### CAUTION: risk of internal back-pressures and projection of components during disassembly.

In abnormal conditions (incorrect installation and/or shutdown and/or standstill conditions), residual pressure, which is not relieved, may be generated inside the pump. Before opening and disassembling the pump, it is necessary to secure the pump casings with a suitable ratchet strap and wear suitable Personal Protective Equipment (PPE).

- 6.4.1b Disconnect the suction and delivery pipes of the pump fluid.

- 6.4.1c Disassemble and remove the pump from the place of installation using suitable lifting equipment and adequately drain the product circuit according to the treated product.



### CAUTION: risk of leakage of the washing and/or contaminated liquid.

The pump is not self-draining, pay attention during handling and disassembly.

- 6.4.1d Use the relevant Spare Parts table for the pump disassembly and reassembly sequence to access the internal parts of the treated operations.





## 6.4.2 INTERNAL CLEANING OF THE PRODUCT CIRCUIT

The internal cleaning of the pump must be carried out periodically every 20,000,000 operating cycles to allow visual inspection and safe use of the pump. The presence of dust and/or deposits on the external surfaces of the pump can negatively affect process temperatures.



**CAUTION: risk of overheating and, in environments with a potentially explosive atmosphere, risk of fire.** In environments with a potentially explosive atmosphere, the presence of dust can even compromise safety.

Safety requirements for the operation:

- Disassembled pump;
- Pump with the external parts cleaned/washed;
- Pump with internal product circuit washed and decontaminated (according to the pumped liquid).
- Pump with product circuit drained of the contaminated washing liquid.

Proceed as follows to clean the inside of the product circuit of the pump:

6.4.2a On CUBIC 15 pumps disassemble the suction and delivery manifolds by removing all fixing screws.

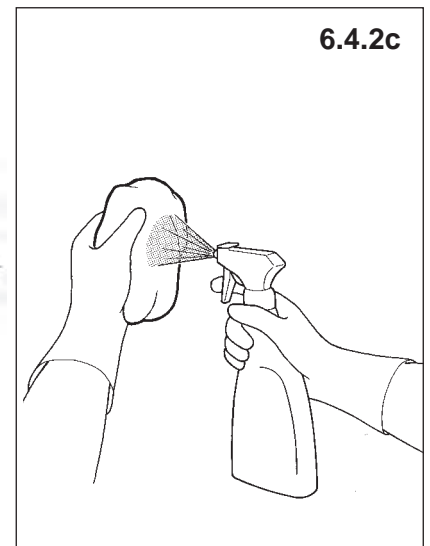
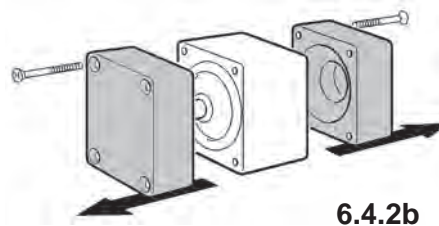
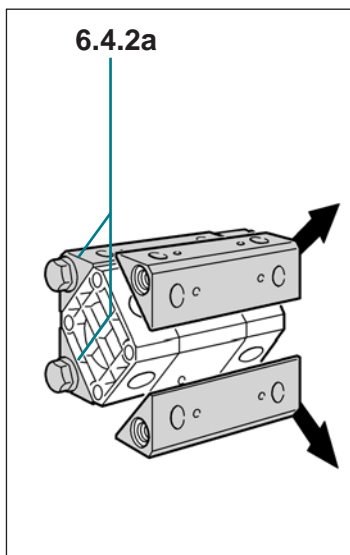

**CAUTION: risk of internal back-pressures and projection of components during disassembly.**

In abnormal conditions (incorrect installation and/or shutdown and/or standstill conditions), residual pressure, which is not relieved, may be generated inside the pump. Before opening and disassembling the pump, it is necessary to secure the pump casings with a suitable ratchet strap and wear suitable Personal Protective Equipment (PPE).

6.4.2b Disassemble the fixing screws and remove the pump casings.

6.4.2c Check for solid deposits inside the pump and, if present, remove them and clean the internal surfaces of the pump using a disposable cloth dampened with detergent (suitable for the treated product) and compatible with the construction materials of the pump and with the work environment.



**CAUTION: risk of damage and/or fire.**

Do not use detergents that are not compatible with the construction materials of the pump, solvents or flammable substances.

6.4.2d Visually inspect the internal surfaces in contact with the product and make sure that there are no abrasions, corrosion, cracks and/or damages to the components.



The internal cleaning of the product circuit of the pump is completed.

### 6.4.3 CHECK AND/OR REPLACEMENT OF VALVES (Suction and Delivery)

The suction and delivery valves (ball and ball seats) are components subject to wear. Their duration is strongly affected by the conditions of use and by the chemical and physical stresses. The suction and delivery valves must be periodically checked every 10,000,000 cycles of operation to ensure correct operation of the product seals and the best performance of the pump.

#### Safety requirements before starting the operation:

- Pump removed from the working position and residual pressure inside the air circuit discharged;
- Pump with the external parts cleaned/washed;
- Pump with internal product circuit washed and decontaminated (according to the pumped liquid).
- Pump with product circuit drained of the contaminated washing liquid.

Proceed as follows to check and/or replace the pump valves:

6.4.3a On CUBIC 15 pumps disassemble the suction and delivery manifolds by removing all fixing screws.

6.4.3b Remove the seats and the balls of the delivery and suction valves, and clean them with a cloth dampened with suitable detergent and/or replace them with Original Spare Parts of the same type and material ([see the Spare Parts Manual](#)).

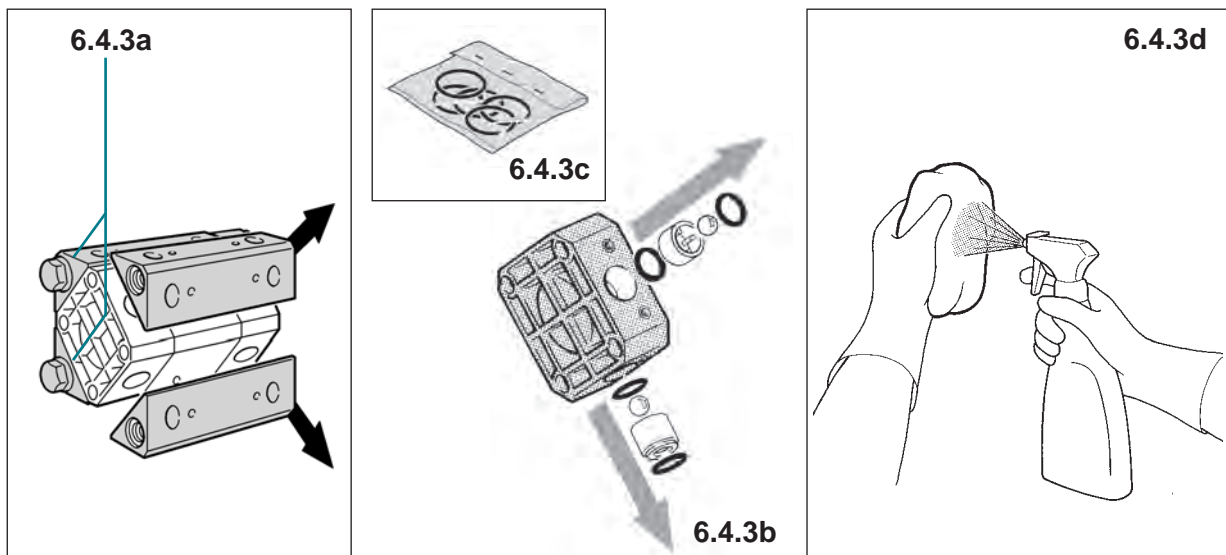

#### **CAUTION: risk of damage and/or fire.**

Do not use detergents that are not compatible with the construction materials of the pump, solvents or flammable substances.

6.4.3c Check the condition of the gaskets and, if necessary, replace them with Original Spare Parts of the same type and material ([see the Spare Parts Manual](#)).

6.4.3d Check that there are no solid deposits inside the valves; otherwise, remove them with a disposable clean cloth dampened with detergent (suitable for the treated product).

**The check and/or replacement of the pump valves is completed.**

#### 6.4.4 CHECK AND/OR REPLACEMENT OF DIAPHRAGMS (End of Life)

The diaphragms (internal and in contact with the product) are components subject to wear. Their duration is strongly affected by the conditions of use and by the chemical and physical stresses. Tests carried out on thousands of installed pumps (with a head of 0.5 m at 20°C) have shown that normal life exceeds 100,000,000 (one hundred million) cycles.



**CAUTION:** For safety reasons, in environments with a potentially explosive atmosphere, the pump diaphragms must be disassembled and checked **every 10,000,000 (ten million) cycles** and **preventively replaced every 20,000,000 (twenty million) cycles**.

MANDATORY OPERATIONS	SCHEDULING OF OPERATIONS		
	every 500 hours	CHECK every 10,000,00 cycles	REPLACEMENT every 20,000,00 cycles
INTERNAL CLEANING AND CHECK	✓	--	--
DIAPHRAGM CHECK	--	✓	--
DIAPHRAGM REPLACEMENT	--	--	✓

Safety requirements before starting the operation:

- Pump removed from the working position and residual pressure inside the air circuit discharged;
- Pump with the external parts cleaned/washed;
- Pump with internal product circuit washed and decontaminated (according to the pumped liquid).
- Pump with product circuit drained of the contaminated washing liquid.

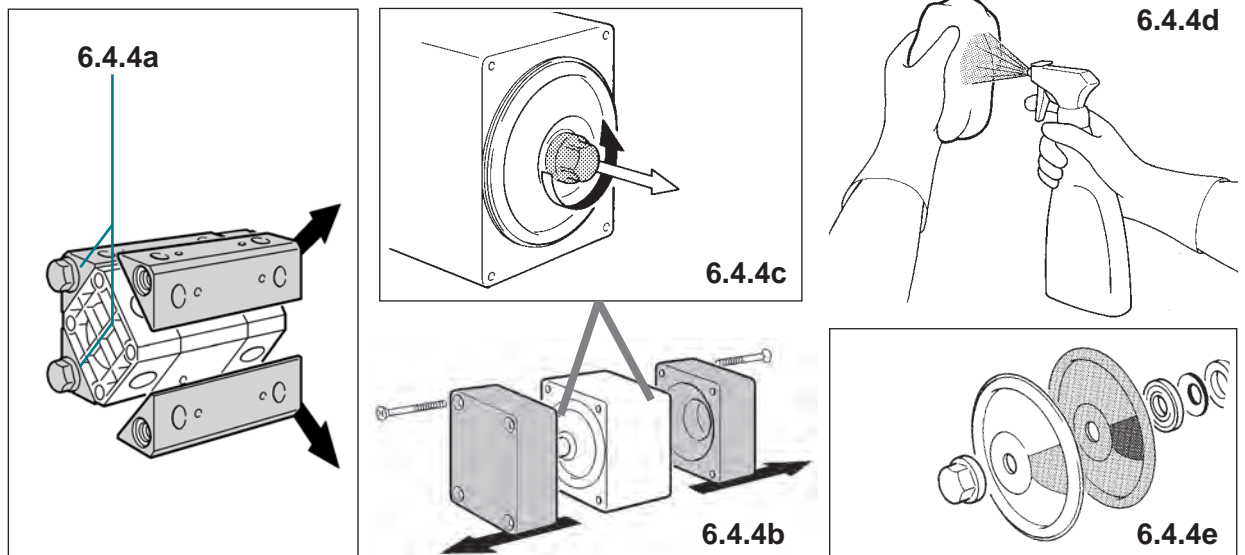

6.4.4a For CUBIC 15 pumps, remove all fixing screws and remove the manifolds.



**CAUTION: risk of internal back-pressures and projection of components during disassembly.**

In abnormal conditions (incorrect installation and/or shutdown and/or standstill conditions), residual pressure, which is not relieved, may be generated inside the pump. Before opening and disassembling the pump, it is necessary to secure the pump casings with a suitable ratchet strap and wear suitable Personal Protective Equipment (PPE).

6.4.4b Disassemble the fixing screws and remove the pump casings.

6.4.4c Remove the diaphragm locking cap of both circuits.

6.4.4d Check that there are no solid deposits; otherwise, remove them with a disposable clean cloth dampened with a detergent suitable for the treated product, and clean the diaphragms.



**CAUTION: risk of damage and/or fire.**

Do not use detergents that are not compatible with the construction materials of the pump, solvents and/or flammable substances.

6.4.4e Remove the diaphragms from both sides of the pump.

6.4.4f Check the condition of the diaphragms and that there are no yield points, cracks or breaking points. Based on the outcome of the performed checks and the timing provided for the replacement of the diaphragms, establish whether to reuse them and/or replace them with Original Spare Parts of the same type and material *(see the Spare Parts Manual)*.



**CAUTION: risk of fluid leakage.**

Do not use the pump if the diaphragms are compromised, damaged, or of a different type and material to the original (reported on the Composition Code) or that have reached their “End of Life” as indicated by the Manufacturer.

**The replacement of the pump diaphragms is completed.**

**6.4.5 PUMP RE-ASSEMBLY**

To reassemble the pump after internally cleaning and checking, and/or replacing the valves and diaphragms, proceed as follows:

6.4.5a Check the condition of the pump pressure static seal O-ring gaskets (they must not be dry, deformed or crushed); otherwise, replace them with Original Spare Parts *(see the Spare Parts Manual)*.

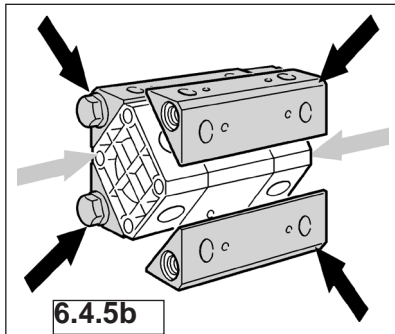

Dimensione	Torcenza	Dimensione	Torcenza
M6	5,0	M12	20,0
M8	10,0	M14	30,0
M10	15,0	M16	40,0

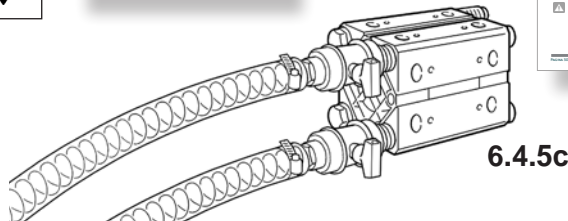

**4.3 POSIZIONAMENTO E INSTALLAZIONE**

La posizione di installazione deve essere a 90° rispetto all'angolo di attacco per evitare vibrazioni e rumore.

**4.4 ALLACCIAMENTO PNEUMATICO**

La posizione di allacciamento dell'ingrediente pneumatico deve essere a 90° rispetto all'angolo di attacco per evitare vibrazioni e rumore.



**NOTE**

The PTFE static seal O-rings must be mandatorily replaced after every disassembly.

6.4.5b Reassemble the pump in the reverse order to that described above and tighten the fixing bolts progressively and uniformly, observing the tightening torques indicated by the Manufacturer *(see 6.3.2 TIGHTENING TABLE page 47)*.



**CAUTION: risk of stress corrosion cracking phenomena and sudden breakages.**

Excessive tightening (especially on plastic pumps) can cause dangerous tensions on some components and sudden breakages that cannot be attributed to construction defects.

6.4.5c Reposition and connect the pump to the system and pneumatic supply circuit as described in *Sections 4.3 and 4.4*.

**The maintenance of the product circuit of the pump is completed.**



## 6.5 AIR CIRCUIT MAINTENANCE



This operation is reserved for trained and qualified maintenance technicians equipped with appropriate Personal Protective Equipment (PPE); *see Technical and Safety Data Sheets* of the liquid treated.



**CAUTION: risk of contact with toxic or corrosive fluids.**

The air circuit maintenance involves the replacement of the pneumatic exchanger, which is necessary in exceptional cases due to incorrect installations in very dusty environments, in the presence of saturated vapours that can damage the internal circuit or, if following the breakage of the diaphragms, the corrosive fluid has entered the pneumatic circuit.



**CAUTION: danger of damage to the internal pneumatic circuit.**

For installations in environments with a harsh atmosphere (dust, vapours or saturated vapours), it is necessary to install a pipe and fittings (of suitable materials) to bring the air discharge point outside the operating environment.

*Safety requirements before starting the operation:*

- Pump shut down with air supply disconnected and interlocked and residual pressure discharged;
- Pump with the external parts cleaned/washed;
- Pump with internal product circuit washed and decontaminated (according to the pumped liquid);
- Pump with product circuit drained of the contaminated washing liquid.
- Closed product sectioning valves (suction and delivery);
- Pump and suction and delivery circuits cooled.

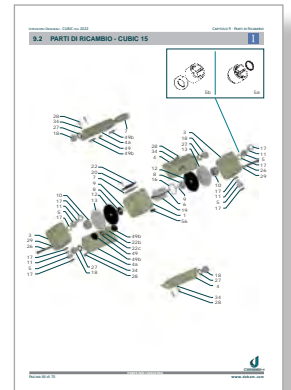
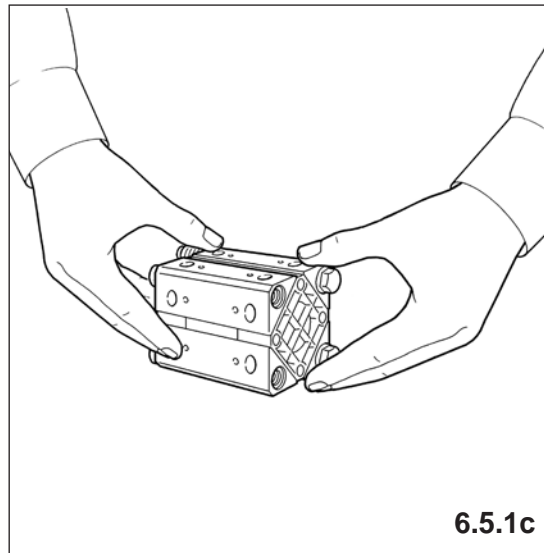
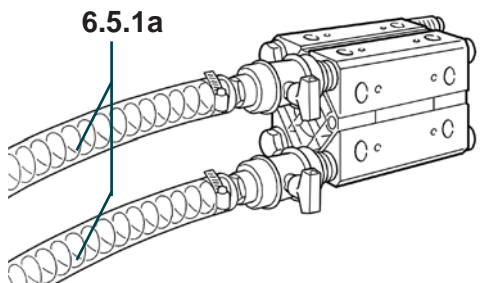
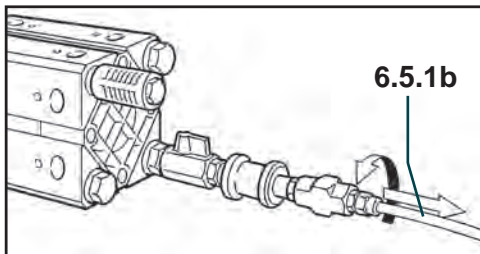

6.5.1d

### 6.5.1 PUMP DISASSEMBLY

To replace the pneumatic exchanger of the air circuit it is necessary to disassemble the pump as follows:

- 6.5.1a Disconnect the suction and delivery pipes of the pump fluid.
- 6.5.1b Disconnect the compressed air supply pipe from the pump.
- 6.5.1c Remove the pump from the installation site and dismantle it.



**CAUTION: risk of contaminated liquid leaking; risk of injuries and/or harm to health.**

The pump is not self-draining, pay attention during disassembly and handling. Should the pump be returned to the Manufacturer or an Authorised Assistance Centre, it must first be emptied of the product or any detergents. If toxic, noxious or other types of health-harming products have been used, the pump must be suitably treated and washed before it is sent.

- 6.5.1d Use the relevant Spare Parts table for the pump disassembly and reassembly sequence to access the internal parts of the treated operations.

## 6.5.2 COAXIAL PNEUMATIC EXCHANGER REPLACEMENT

All CUBIC series pumps house a coaxial pneumatic exchanger; to replace the pneumatic exchanger, proceed as follows:



### CAUTION: risk of contamination, injuries and/or harm to health.

Should the pump be returned to the Manufacturer or an Authorised Assistance Centre, it must first be emptied of the product or any detergents.

If toxic, noxious or other types of health-harming products have been used, the pump must be suitably treated and washed before it is sent.

### Safety requirements for the operation:

- Pump removed from the working position and residual pressure inside the air circuit discharged;
- Pump with the external parts cleaned/washed;
- Pump with internal product circuit washed and decontaminated (according to the pumped liquid).
- Pump with product circuit drained of the contaminated washing liquid.

6.5.2a For CUBIC 15 pumps, disassemble the suction and discharge manifolds by removing all fixing screws.

6.5.2b Disassemble the fixing screws and remove the pump casings.

6.5.2c Remove the diaphragm locking cap of both circuits and remove the pump diaphragms.

6.5.2d Disassemble the coaxial pneumatic exchanger by removing the fastening elements.

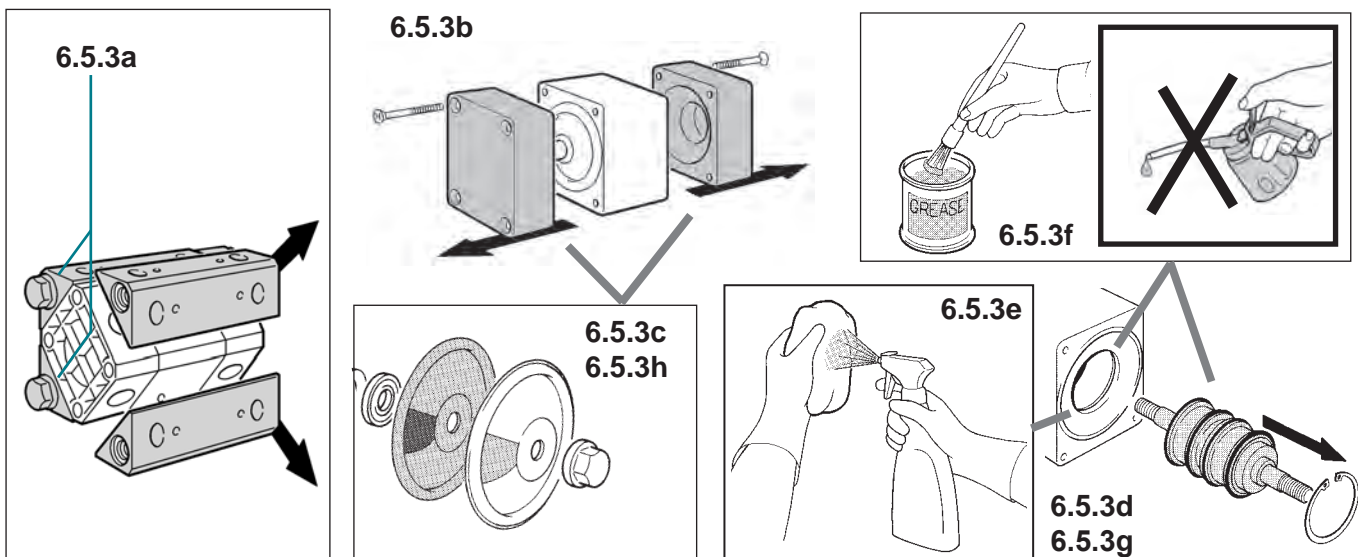

6.5.2e Clean the central and the diaphragms using a disposable clean cloth dampened with a suitable detergent (for the construction material of the pump and the treated product).



### CAUTION: risk of damage and/or fire.

Do not use detergents that are not compatible with the construction materials of the pump, solvents or flammable substances.

6.5.2f Spread a layer of suitable grease( MOLYKOTE®) over the bore of the central body.



### CAUTION: danger of pump blocking.

Do not use any type of oil; the oil removes the grease and once discharged, it causes consequent blockage due to lack of lubrication.

6.5.2g Replace the exchanger and the connection shaft with an Original Spare Part having the same characteristics (construction materials of the components).



### CAUTION: risk of malfunctioning and blocking of the pump.

The pneumatic exchanger must not be opened to avoid incorrect reassembly and consequent malfunction of the pump.

6.5.2h Reassemble the diaphragms and tighten the relative fixing cap.

**The replacement of the coaxial pneumatic exchanger pumps is completed.**



### 6.5.3 PUMP RE-ASSEMBLY

After replacing the pneumatic exchanger, reassemble the pump as follows:

- 6.5.3a Check the condition of the pump pressure static seal O-ring gaskets (they must not be dry, deformed or crushed); otherwise, replace them with Original Spare Parts (*see the Spare Parts Manual*).



#### NOTE

The PTFE static seal O-rings must be mandatorily replaced after every disassembly.

- 6.5.3b Reassemble the pump in the reverse order to that described above and tighten the fixing bolts progressively and uniformly, observing the tightening torques indicated by the Manufacturer (*see 6.3.2 TIGHTENING TABLE page 47*).



#### CAUTION: risk of stress corrosion cracking phenomena and sudden breakages.

Excessive tightening (especially on plastic pumps) can cause dangerous tensions on some components and sudden breakages that cannot be attributed to construction defects.

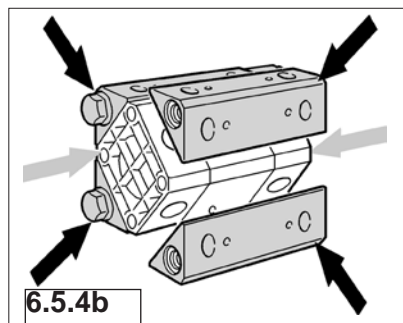

6.5.4b

**6.5.4b**

TABELLA DEI TORQUE	
ATTENZIONE: per evitare fenomeni di sovraccarico e rotture, procedere al serraggio dei bulloni in modo graduale e uniforme, osservando i valori indicati nella tabella sottostante.	
Dimensione	Torque
M6	10 Nm
M8	15 Nm
M10	20 Nm
M12	25 Nm
M16	40 Nm
M20	60 Nm
M24	80 Nm



6.5.4a

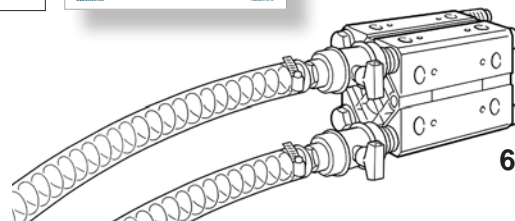

6.5.4c

4.3 POSIZIONAMENTO E INSTALLAZIONE

4.4 ALLACCIAMENTO PNEUMATICO

- 6.5.3c Reposition and connect the pump to the system and pneumatic supply circuit as described in *Sections 4.4 and 4.5*.

The replacement of the pneumatic exchanger and the reassembly of the pump is completed.



## CHAPTER 7

The following instructions are intended exclusively for authorised skilled Maintenance Engineers who know and comply with the contents of the Original Instructions. In the event of abnormal behaviour and in order to fix faults, please refer to the following troubleshooting instructions. The graphic setting is in table format with direct correspondence between Anomaly, Possible Cause and Suggestion.



### NOTE

For more serious problems, we strongly recommend contacting the DEBEM SERVICE DEPARTMENT or an Authorised Assistance Centre; our Engineers will provide you with assistance as quickly as possible.



### CAUTION

Before performing any operation and accessing the pump, it is necessary to:

- disconnect and interlock the compressed air and discharge the residual pressure from the pneumatic circuit inside the pump;
- disconnect the product on/off valves (suction and delivery);
- if necessary, clean the outside of the pump;
- if necessary, wash (decontaminate) the product circuit inside the pump.



### CAUTION: risk of internal back-pressures and projection of components during disassembly.

In abnormal conditions (incorrect installation and/or shutdown and/or standstill conditions), residual pressure, which is not relieved, may be generated inside the pump. Before opening and disassembling the pump, it is necessary to secure the pump casings with a suitable ratchet strap and wear suitable Personal Protective Equipment (PPE).

ANOMALY	POSSIBLE CAUSE	ADVICE
<b>1 The pump does not start.</b>	1.1 No air in the circuit.	<b>1.1a</b> Check circuit, valves, and connections.
	1.2 Air pressure too low.	<b>1.2a</b> Adjust pressure on the relevant reducer.
	1.3 Air flow rate too low.	<b>1.3a</b> Check that piping and accessories have suitable passage.
	1.4 Control valve damaged.	<b>1.4a</b> Check and replace the control valve.
	1.5 Delivery or suction of the closed pump.	<b>1.5a</b> Disconnect intake and delivery hoses and check if the pump starts.
	1.6 Pump pneumatic exchanger damaged.	<b>1.6a</b> Replace exchanger; check whether the air discharge is obstructed by ice. If this is the case, it must be removed (see paragraph air supply).
	1.7 Broken diaphragm.	<b>1.7a</b> Check if any air comes out from the product delivery pipe; if so, replace diaphragm.
<b>2. The pump exchanges but does not move the fluid.</b>	2.1 The balls do not close.	<b>2.1a</b> Dismantle the manifolds (on CUBIC 15), and clean the seats or replace the balls and seats.
	2.2 Suction height too high.	<b>2.2a</b> Reduce suction height.
	2.3 Fluid is too viscous.	<b>2.3a</b> Install oversized pipes, especially in the intake and reduce pump cycles.
	2.4 Intake side is obstructed.	<b>2.4a</b> Check and clean.

*Continues on the next page*



Continued from the previous page

ANOMALY	POSSIBLE CAUSE	ADVICE
<b>3. The pump operates in irregular way.</b>	<b>3.1</b> Internal pneumatic exchanger worn or defective.	<b>3.1a</b> Replace pneumatic exchanger.
	<b>3.2</b> Shaft is worn.	<b>3.2a</b> Replace pneumatic exchanger.
	<b>3.3</b> Ice on discharge gate.	<b>3.3a</b> Dehumidify and filter air.
	<b>3.4</b> Lack of air flow.	<b>3.4a</b> Check all air control accessories, especially the quick-release couplings.
	<b>3.5</b> Internal exchanger dirty.	<b>3.5a</b> Replace pneumatic exchanger.
<b>4. Pump cycles are slow.</b>	<b>4.1</b> Fluid is too viscous.	<b>4.1a</b> UNSUITABLE fluid - No remedy.
	<b>4.2</b> Delivery hose is obstructed.	<b>4.2a</b> Check and clean.
	<b>4.3</b> Intake is obstructed.	<b>4.3a</b> Check and clean.
<b>5. The pump does not exchange.</b>	<b>5.1</b> Intake becomes blocked during operation.	<b>5.1a</b> Replace intake hose.
	<b>5.2</b> Dirty air, containing condensation or oil.	<b>5.2a</b> Check air line.
	<b>5.3</b> Air flow pressure too low	<b>5.3a</b> Check pressure with a pressure gauge installed on pump and with the pump running: <a href="#">see fig.4.4.3 page 34</a> . If the pressure at that point is too low compared to the mains pressure, check all air connections, especially those with quick-release couplings. Check that all air control devices have sufficient capacity. <b>CAUTION: in 90% of cases, stall occurrences are caused by snap-on fittings.</b>
	<b>5.4</b> Faulty distributor.	<b>5.4a</b> Replace the distributor.
	<b>5.5</b> Shutdown procedure not complied with.	<b>5.5a</b> Comply with the shutdown procedure, see <a href="#">Section 5.2 pag.40</a> .
<b>6. The pump does not distribute the delivery value stated in the table.</b>	<b>6.1</b> Product intake hose is badly connected.	<b>6.1a</b> Check and reconnect.
	<b>6.2</b> Piping is clogged.	<b>6.2a</b> Check and clean.
	<b>6.3</b> Fluid is too viscous.	<b>6.3a</b> Install larger piping, especially on the intake side and decrease pump cycles.
	<b>6.4</b> Balls do not close.	<b>6.4a</b> Dismantle the manifolds (on CUBIC 15), and clean the seats or replace the balls and seats.
	<b>6.5</b> Air flow too low.	<b>6.5a</b> Check pressure with a pressure gauge installed on pump and with the pump running: <a href="#">see fig.4.4.3 page 34</a> . If the pressure at that point is too low compared to the mains pressure, check all air connections, especially those with quick-release couplings. Check if all air control devices have sufficient flow rate. <b>CAUTION: in 90% of cases, stall occurrences are caused by snap-on fittings.</b>
	<b>6.6</b> Probable pressure losses on the air supply line to the pump.	<b>6.6a</b> <b>Check the pressure at the pump inlet.</b> Eliminate pressure losses on the compressed air supply line to the pump.
	<b>6.7</b> Possible back pressure or heads higher than those allowed by the Model of the pump used based on the flow rate delivered.	<b>6.7a</b> <b>Check the actual product pressure distributed by the outlet pump to the delivery manifold.</b> Eliminate backpressures on the product delivery line or use the pump model suitable for the desired flow rate.

## CHAPTER 8

This chapter deals with the manufacturer's plans for the decommissioning and end-of-life disposal of CUBIC series pumps.

THIS PART INCLUDES THE FOLLOWING TITLES		PAGE
<b>8.1</b>	<b>DECOMMISSIONING AND WASHING FORM</b>	<b>59 - 60</b>
<b>8.2</b>	<b>DISPOSAL</b>	<b>61 - 62</b>

Below is a description of how to behave in each of the phases listed above.

## 8.1 DECOMMISSIONING AND WASHING FORM



This operation is reserved for trained and qualified maintenance technicians equipped with appropriate Personal Protective Equipment (PPE); (see *Technical and Safety Data Sheets* of the liquid treated).



**CAUTION: risk of contact with toxic or corrosive fluids.**

In case the pump remains inactive for long periods or leaks or malfunctions may affect the safety of the pump or system, or at the "End of Life" of the diaphragms, it is necessary to decommission it until the restoration of the necessary safety conditions and optimal operation of the same.



**CAUTION: risk of fluid leakage, risk of fire.**

It is forbidden to use the pump in a compromised condition or with diaphragms that have reached "End of Life" as indicated by the manufacturer (see *Section 4.4 - End of Life*).

### 8.1.1 DECOMMISSIONING DUE TO INACTIVITY

Before decommissioning due to long periods of inactivity, it is necessary to proceed as follows:

- 8.1.1a Clean the external part of the pump using cloths dampened with suitable detergent (compatible with the construction materials of the pump).
- 8.1.1b Wash the inside of the pump (washing and decontamination according to the used fluid) with a suitable detergent (compatible with the construction materials).
- 8.1.1c Close the product suction and delivery on/off valves mounted on the pump.
- 8.1.1d Close the air supply using the 3-way valve and discharge the residual pressure from the pneumatic circuit inside the pump and then disconnect the air supply on the network node.



**CAUTION: risk of internal back-pressures and projection of components during disassembly.**

In abnormal conditions (incorrect installation and/or shutdown and/or standstill conditions), residual pressure, which is not relieved, may be generated inside the pump. Before opening and disassembling the pump, it is necessary to secure the pump casings with a suitable ratchet strap and wear suitable Personal Protective Equipment (PPE).

- 8.1.1e Indicate the "DECOMMISSIONING" status on the pump with a specific signal.
- 8.1.1f Should it be necessary to store the pump or send it back to the Manufacturer, proceed with the disassembly and emptying as described in *points 8.1.2 and 8.1.4*.

### 8.1.2 PUMP DISASSEMBLY FROM THE WORKING POSITION

Proceed as follows to disassemble the pump from the working position.

*Safety requirements before starting the operation:*

- Pump shut down with air supply disconnected and interlocked and residual pressure discharged;
- Pump with the external parts cleaned/washed;
- Pump with internal product circuit washed and decontaminated (according to the pumped liquid);
- Pump with product circuit drained of the contaminated washing liquid.
- Closed product sectioning valves (suction and delivery);
- Pump and suction and delivery circuits at ambient temperature

- 8.1.2a Disconnect the suction and delivery pipes of the pump fluid.
- 8.1.2b Disconnect the compressed air supply pipe from the pump.
- 8.1.2c Disassemble and remove the pump from the place of installation using suitable lifting equipment and adequately drain the product circuit according to the treated product.



**CAUTION: risk of leakage of the washing and/or contaminated liquid.**

The pump is not self-draining, pay attention during handling and disassembly.

### 8.1.3 PUMP STORAGE

The pump must be stored in suitable packaging in a closed and protected environment at temperatures ranging from 5°C to 45°C and a humidity level not above 90%.

The CUBIC series pumps are not self-draining; turn the pump upside down to empty the pump internally of residual wash liquids.

To store, proceed as described in [Section 4.1 STORAGE AND PRESERVATION](#).



**CAUTION: risk of contamination, injuries and/or harm to health.**

Should the pump be stored or returned to the Manufacturer or an Authorised Assistance Centre, it must first be emptied of the product and/or any detergents. If toxic, noxious, or other types of health-harming products have been used, the pump must be suitably treated and washed and then emptied before it is stored or sent.

**The pump decommissioning is completed.**

### 8.1.4 PUMP WASHING FORM

Before returning the pump to the Manufacturer for any maintenance or as returned goods, it is always necessary to thoroughly wash the product circuit to remove any residual contaminants and chemical agents and then empty it.

The CUBIC series pumps are not self-draining; turn the pump upside down to completely empty the internal flushing liquids.

Delivery of the washed and emptied pump to the Manufacturer must always be accompanied by the [“Pump Washing Form”](#) (see pages below), duly completed and signed by the Manager who certifies the effective decontamination from all possible toxic, irritant and polluting agents it came into contact with.



**CAUTION: risk of contamination, injuries and/or harm to health.**

Failure to submit the “Pump Washing Form” duly completed and signed will not allow for adequate treatment in compliance with current safety regulations and does not authorise the Manufacturer to accept the goods even on consignment.

## 8.2 DISPOSAL



This operation is reserved for trained and qualified maintenance technicians, equipped with appropriate Personal Protective Equipment (PPE); (see *Technical and Safety Data Sheets of the liquid treated*).



**CAUTION: risk of contact with toxic or corrosive fluids.**

The nameplate of the CUBIC series pump shows the component materials covered in *Section 2.2 PUMP CONFIGURATION CODE* so that you can carry out any separation and disposal by homogeneous material types.

The CUBIC series pumps are not made up of dangerous parts or parts that require conditioning treatment; however, they may be contaminated due to the environment of use or the type of fluid used. In any case, when they are worn out, they must be disposed of and dismantled in the following manner:



**CAUTION: risk of serious injuries, harm to health.**

Do not dispose of the pump with residues of dangerous fluids or with surfaces contaminated by toxic, irritating and/or health-damaging fluids.

- 8.2.1 Wash, remove or decontaminate appropriately any residues of product or contaminant dangerous to human contact and/or the environment, working according to the indications given in the relevant Technical Data Sheet or Safety Data Sheet for the product used.
- 8.2.2 Wash the inside of the pump product circuit (washing and decontamination according to the used fluid) with a suitable detergent or decontaminant.
- 8.2.3 Close the product suction and delivery on/off valves of the pump.
- 8.2.3a Close the air supply using the 3-way valve and discharge the residual pressure from the pneumatic circuit inside the pump and then disconnect the air supply on the network node.
- 8.2.4 Disconnect the compressed air supply pipe from the pump.

### 8.2.5 PUMP DISASSEMBLY

To disassemble the pump, proceed as follows:

*Safety requirements before starting the operation:*

- Pump shut down with air supply disconnected and interlocked and residual pressure discharged;
  - Pump with the external parts cleaned/washed;
  - Pump with internal product circuit washed and/or decontaminated (according to the pumped liquid).
  - Closed product sectioning valves (suction and delivery);
  - Pump and suction and delivery circuits cooled.
- a. Disconnect the suction and delivery pipes of the pump fluid.
  - b. Disconnect the compressed air supply pipe from the pump.
  - c. Disassemble and remove the pump from the place of installation using suitable lifting equipment.



**CAUTION: risk of leakage of the washing and/or contaminated liquid; risk of injuries and/or harm to health.** The pump is not self-draining, pay attention during handling and disassembly. If toxic, noxious, or other types of health-harming products have been used, the pump must be suitably treated and washed before it is stored or sent.

- 8.2.6 Separate pump components by *type and homogeneous materials* (see Section 2.2).



**CAUTION: risk of internal back-pressures and projection of components during disassembly.**

In abnormal conditions (incorrect installation and/or shutdown and/or standstill conditions), residual pressure, which is not relieved, may be generated inside the pump. Before opening and disassembling the pump, it is necessary to secure the pump casings with a suitable ratchet strap and wear suitable Personal Protective Equipment (PPE).

- 8.2.7 For disposal, contact authorised waste collection companies.



**CAUTION: danger of pollution and/or accidents.**

Make sure no small or large components, which may cause pollution, accidents, or damage, either direct or indirect, are dispersed in the environment.

**The pump demolition and disposal is completed.**



**Documento accompagnatorio a DDT in c.to riparazione  
( Obbligatorio\* )**

<b>Azienda</b>	
<b>Persona di riferimento</b>	
<b>Telef.</b>	
<b>Email.</b>	
<b>D.D.T. di riferimento</b>	
<b>Dati Pompa</b>	
<b>Modello</b>	
<b>Codice</b>	
<b>N° Matricola/seriale</b>	
<b>Interventi precedenti effettuati da:</b>	<b>in data:</b>
<b>Problematica riscontrata</b>	
<b>Tipologia dei fluidi interessati al trasferimento con la pompa (se acidi specificare la % ) campi obbligatori (*) (**)</b>	
<b>1:</b>	<b>5:</b>
<b>2:</b>	<b>6:</b>
<b>3:</b>	<b>7:</b>
<b>4:</b>	<b>8:</b>
<b>Temperatura di esercizio : °C =</b>	
<b>Pressione di azionamento : min./max.</b>	
<b>ATTENZIONE</b>	
<p><b>** Si dichiara che la pompa in oggetto è stata accuratamente pulita e lavata da ogni traccia dei prodotti per cui è stata utilizzata ed è quindi priva di inquinanti e/o prodotti dannosi per l'ambiente le cui caratteristiche sono specificatamente sopra descritte.</b></p> <p><b>* La mancanza della compilazione di questo format comporterà l'impossibilità ad effettuare il preventivo di riparazione con la conseguente resa della merce a carico del mittente. DEBEM si riserva diritto di non effettuare riparazioni su pompe dedicate al trasferimento di fluidi potenzialmente pericolosi per la salute dell'operatore e dell'ambiente. DEBEM si attiene scrupolosamente alle normative vigenti in merito allo smaltimento rifiuti e non è autorizzata smaltire fluidi di alcun genere e/o tipologia.</b></p> <p><b>Le date di consegna verranno concordate e comunicate di volta in volta con il nostro personale.</b></p> <p><b>I tempi necessari per le riparazioni saranno concordati con il nostro personale</b></p>	
Data    _/_/___	
Timbro e firma _____	



Below are the Spare Parts Tables for the CUBIC series pumps.

The components of the CUBIC series pumps, in addition to fulfilling their primary function, are designed and constructed to fulfil important general and fluid-processing safety functions; when replacing worn parts, only use original spare parts suitable for the pump model and markings.



**WARNING: danger of lack of safety**

Failure to comply with the above may result in dangers for the Operator, Technicians, people, the pump and/or the installation environment, for which the Manufacturer is not responsible. Furthermore, failure to comply with the safety instructions exposes the pump to dangerous contamination and, more generally, can lead to the safety requirements of the pump and the processed fluid being compromised for reasons not attributable to the manufacturer.

When ordering spare parts it is always necessary to include all the items shown in the example below:

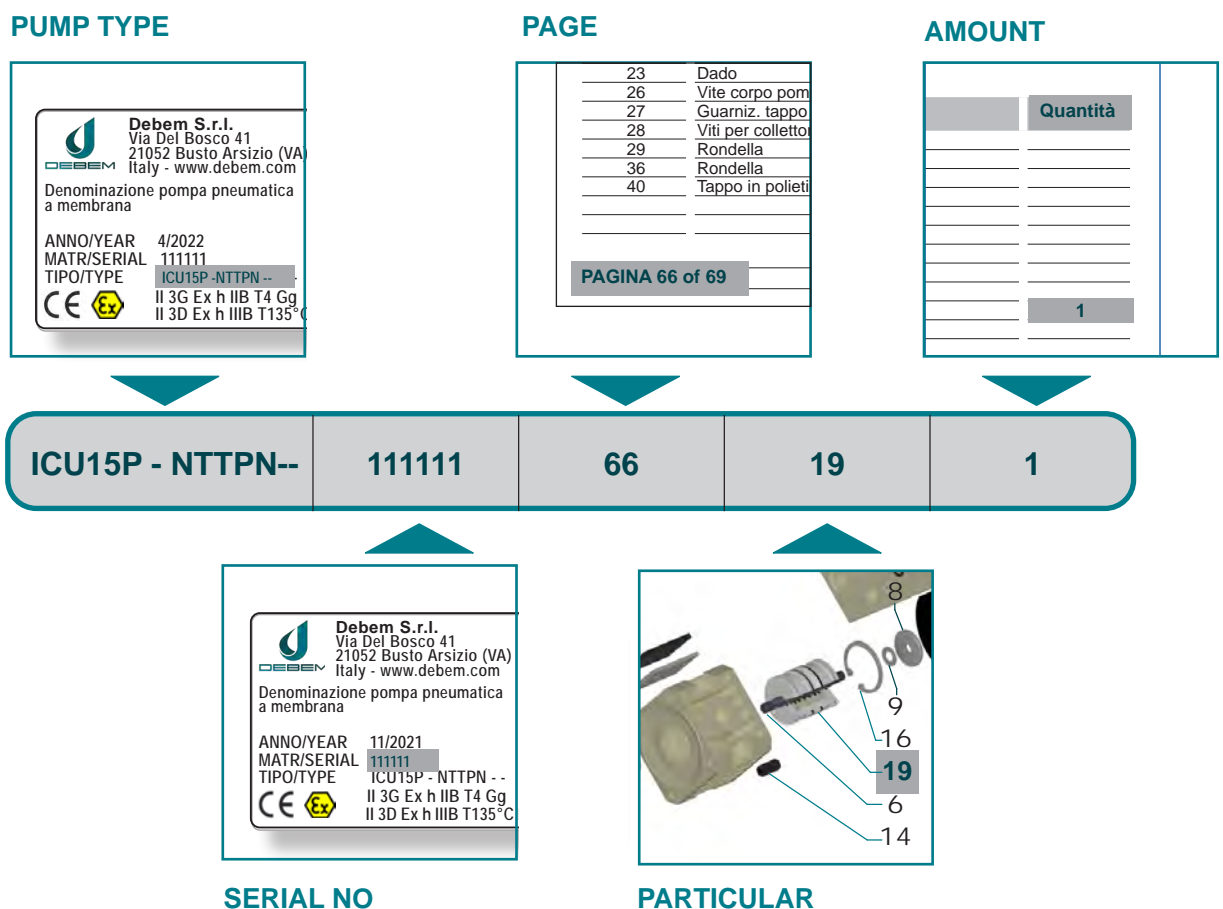

# 9.1 MIDGETBOX - SPARE PARTS

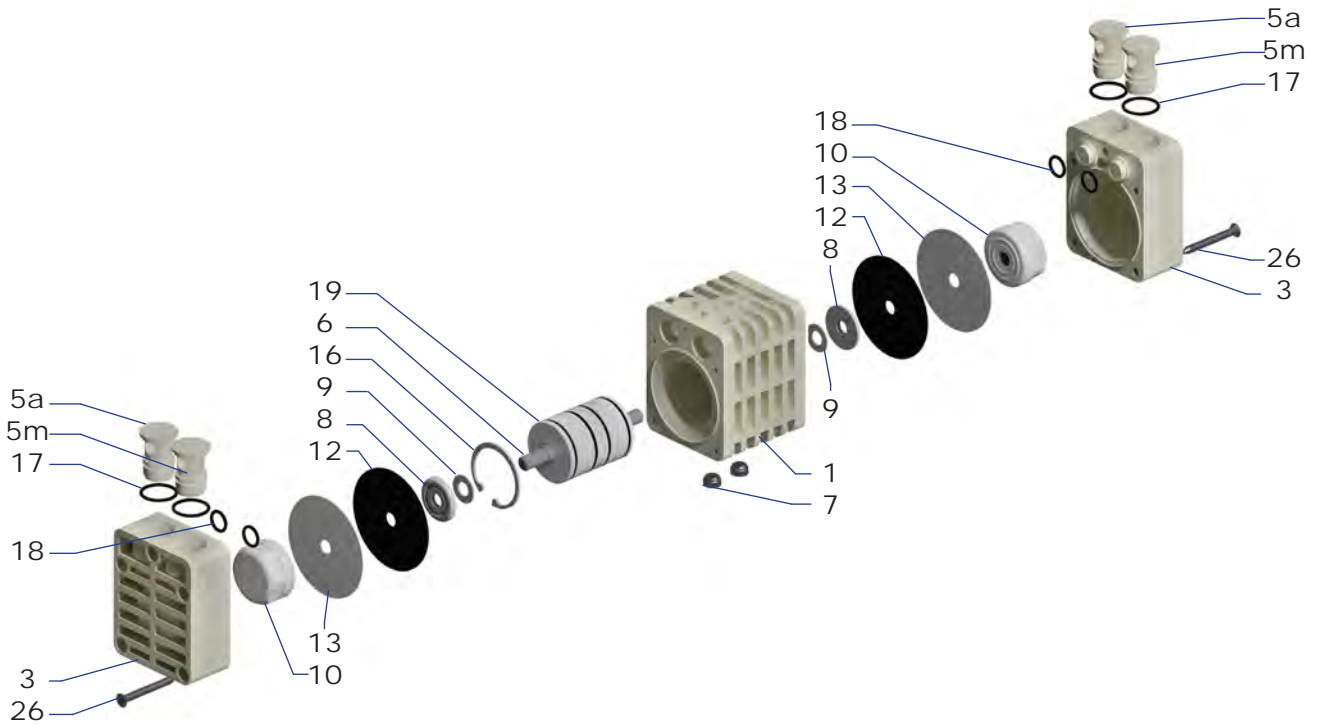
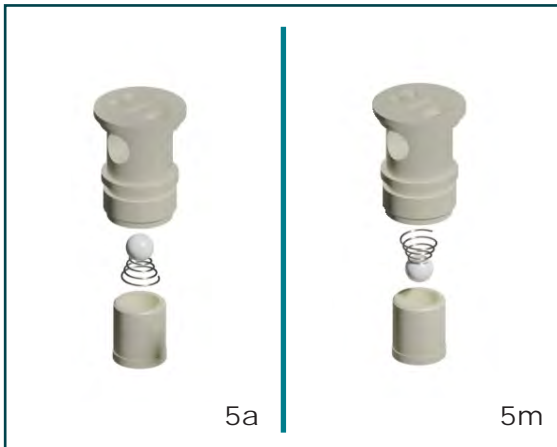





# 9.2 CUBIC 15 - SPARE PARTS

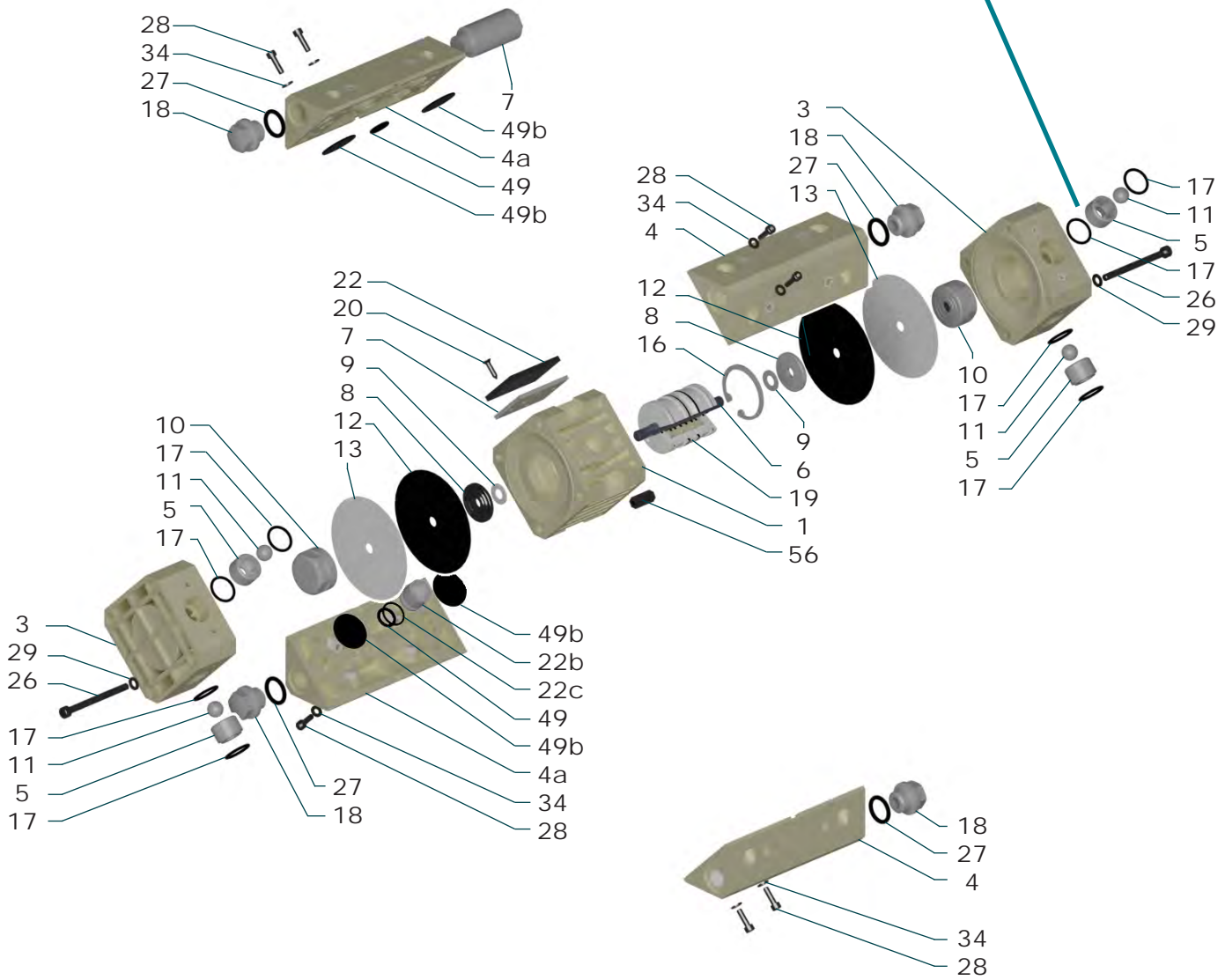
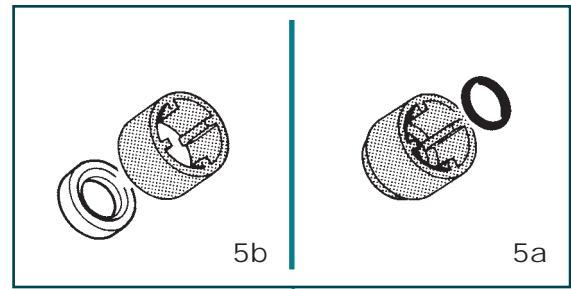

# CUBIC 15 - SPARE PARTS



Position	DESCRIPTION	Qty
1	Central block	1
3	Pump body with inserts	2
4	Delivery and suction manifold with inserts	2
4a	Discharge/supply manifold with inserts	2
5	Ball seat	4
5a	Ball seat configuration with O-ring	4
5b	Ball seat configuration with wafer	4
6	Shaft	1
7	Filter silencer	1
8	Internal plate	2
9	Belleville washer	2
10	Cap	2
11	Balls	4
12	Internal diaphragm	2
13	External diaphragm	2
16	Seeger	1
17	Ball seat gasket	8
18	Manifold plug	4
19	Pneumatic exchanger	1
20	Air discharge cover screw	4
22	Air discharge cover	1
22b	Air inlet adapter	1
22c	Adapter gasket	1
26	Pump body screw	8
27	Collector plug gasket	4
28	Manifold screw	16
29	Pump body flat washer	8
34	Manifold flat washer	16
49	O-ring	2
49b	Air-side flat gasket	4
56	Coupling sleeve	4



**NOTES**



Lined area for notes, consisting of multiple horizontal lines.









**AIR-OPERATED**

**P U M P S**  
s e r i e s

CUBIC rev. 2022

# CUBIC

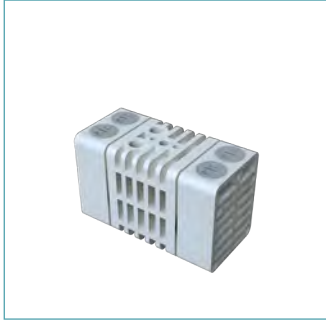

Authorised **RESELLERS:**

Authorised **ASSISTANCE CENTRES:**



RESELLER STAMP: \_\_\_\_\_



**DEBEM**  
MADE IN ITALY

DEBEM **s.r.l.** - Via Del Bosco, 41 - Busto Arsizio (VA) ITALY  
Tel. (+39) 0331/074034 - fax (+39) 0331/074036 - info@debem.it - www.debem.com

**INDUSTRIAL PUMPS**

CHEMICAL / PAINTING / PRINTING / WATER TREATMENT / GALVANIC / TEXTILE / CERAMIC / AUTOMOTIVE / MECHANICAL / OIL & GAS

info@debem.it - www.debem.com