

EP

ELETTROPOMPE IN ACCIAIO INOX AISI 316 STAINLESS STEEL AISI 316 ELECTRIC PUMPS



EP 80 Inox



EP SENIOR 1"1/2
EP MASTER 2"



EP JUNIOR 1"1/4



EPH-EP NEOS 3/4"

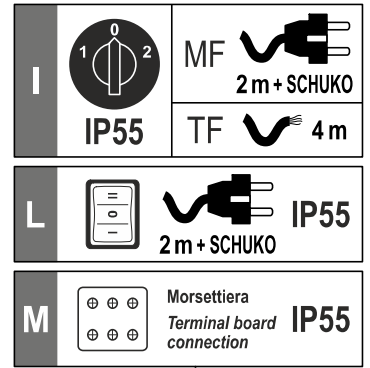

ELETTROPOMPE MONOFASE (MF) O TRIFASE (TF) - 50 Hz / SINGLE-PHASE (MF) OR THREE PHASE (TF) ELECTRIC PUMPS - 50 Hz

Modello Type	Maniglia Handle	Motore Motor	Volt	Hz	kW	Giri/min. RPM	H = Prevalenza (metri) / Head (meters) - Q = Portata (l/min.) / Capacity (l/min.)										H																										
							0	5	10	15	18	22	30	35	40	50		55																									
EPH NEOS 3/4"	X	L MF	230	50	0.22	2800	29	25	18	13	8	0																															
EP NEOS 3/4"	X	M MF	230	50	0.22	2800	29	25	18	13	8	0																															
	X	I TF	230-400	50	0.26	2800	29	25	18	13	8	0																															
	X	M TF	230-400	50	0.26	2800	29	25	18	13	8	0																															
	X	M TF	230-400	50	0.26	2800	29	25	18	13	8	0																															
EP JUNIOR 1"1/4	X	I MF	230	50	0.45	2800	58	47	34	22	13	0																															
	X	I MF	110	50	0.45	2800	58	47	34	22	13	0																															
	X	I TF	230-400	50	0.56	2800	58	47	34	22	13	0																															
	X	M TF	230-400	50	0.56	2800	58	47	34	22	13	0																															
EP SENIOR 1"1/2	X	I MF	230	50	0.75	1400	120	105	85	62	45	0																															
	X	I MF	110	50	0.75	1400	120	105	85	62	45	0																															
	X	I MF	230	50	1.1	1400	120	105	85	62	45	0																															
	X	I MF	110	50	1.1	1400	120	105	85	62	45	0																															
	X	I TF	230-400	50	0.75	1400	120	105	85	62	45	0																															
	X	I TF	230-400	50	1.1	1400	120	105	85	62	45	0																															
	X	M TF	230-400	50	1.1	1400	120	105	85	62	45	0																															
EP MASTER 2"	n.d.	I MF	230	50	1.87	1400	230	205	175	140	120	80	0																														
	n.d.	I MF	110	50	1.87	1400	230	205	175	140	120	80	0																														
	n.d.	I TF	230-400	50	1.87	1400	230	205	175	140	120	80	0																														
	n.d.	M TF	230-400	50	1.87	1400	230	205	175	140	120	80	0																														
EP 60 Inox	n.d.	M TF	230-400	50	4.0	1400	350	310	265	220	190	150	60	0																													
EP 70 Inox	n.d.	M TF	230-400	50	5.5	1400	500	455	415	365	330	280	165	90	0																												
	n.d.	M TF	230-400	50	7.5	1400	500	455	415	365	330	280	165	90	0																												
EP 80 Inox	n.d.	M TF	230-400	50	15	1400	900	840	780	720	660	620	500	410	310	110	0																										

ELETTROPOMPE A CORRENTE CONTINUA (CC) CON MANIGLIA/ DIRECT CURRENT ELECTRIC PUMPS (CC) WITH HANDLE

Modello Type	Maniglia Handle	Motore Motor	Volt	A	kW	Giri/min. RPM	H = Prevalenza (metri) / Head (meters) - Q = Portata (l/min.) / Capacity (l/min.)										H																															
							0	2	5	8	10	12	15	20	22	24		30																														
EP NEOS 3/4"	X	M CC	12	26	0.33	2000	25	22	18	11	5	0																																				
	X	M CC	24	14	0.33	2000	25	22	18	11	5	0																																				
EP NEOS 3/4" T	X	M CC	12	36	0.45	3000	34	32	29	25	22	19	15	5	0																																	
	X	M CC	24	22	0.45	3000	34	32	29	25	22	19	15	5	0																																	
EP JUNIOR 1" 1/4	X	M CC	12	32	0.37	2000	43	39	25	11	0																																					
	X	M CC	24	20	0.37	2000	43	39	25	11	0																																					
EP SENIOR 1" 1/2	X	M CC	24	45	1.1	1400	120	115	105	95	85	80	62	30	0																																	
EP MASTER 2"	n.d.	I CC	24	95	1.5	1400	230	220	205	185	175	160	140	95	80	60	0																															

X = disponibile a richiesta / available on request - n.d. = non disponibile / not available

ELETTROPOMPE MONOFASE (MF) O TRIFASE (TF) - 60 Hz / SINGLE-PHASE (MF) OR THREE PHASE (TF) ELECTRIC PUMPS - 60 Hz

Modello Type	Maniglia Handle	Motore Motor	Volt	Hz	kW	Giri/min. RPM	H = Prevalenza (metri) / Head (meters) - Q = Portata (l/min.) / Capacity (l/min.)															
							0	5	10	15	22	24	35	40	45	55	60	H				
EP NEOS 3/4"	X	M	MF	230	60	0.26	3300	36	31	25	17	4	0									
	X	M	MF	110	60	0.26	3300	36	31	25	17	4	0									
	X	I	TF	230-400	60	0.31	3300	36	31	25	17	4	0									
	X	M	TF	230-400	60	0.31	3300	36	31	25	17	4	0									
EP JUNIOR 1"1/4	X	I	MF	230	60	0.54	3300	62	52	40	27	7	0									
	X	I	MF	110	60	0.54	3300	62	52	40	27	7	0									
	X	I	TF	230-400	60	0.67	3300	62	52	40	27	7	0									
	X	M	TF	230-400	60	0.67	3300	62	52	40	27	7	0									
EP SENIOR 1"1/2	X	I	MF	230	60	1.34	1700	150	130	107	80	25	0									
	X	I	MF	110	60	1.34	1700	150	130	107	80	25	0									
	X	I	TF	230-400	60	1.34	1700	150	130	107	80	25	0									
	X	M	TF	230-400	60	1.34	1700	150	130	107	80	25	0									
EP MASTER 2"	n.d.	I	MF	230	60	2.23	1700	250	225	200	165	115	100	0								
	n.d.	I	MF	110	60	2.23	1700	250	225	200	165	115	100	0								
	n.d.	I	TF	230-400	60	2.60	1700	250	225	200	165	115	100	0								
	n.d.	M	TF	230-400	60	2.60	1700	250	225	200	165	115	100	0								
EP 60 Inox	n.d.	M	TF	230-400	60	4.80	1700	385	350	310	265	200	180	60	0							
EP 70 Inox	n.d.	M	TF	230-400	60	9.00	1700	570	530	490	440	360	340	190	100	0						
EP 80 Inox	n.d.	M	TF	230-400	60	18.00	1700	970	910	850	770	670	640	470	380	290	100	0				

X = disponibile a richiesta / available on request - n.d. = non disponibile / not available
 * A richiesta disponibile anche 255-440V e 277-480V / Available on request 255-440V and 277-480V

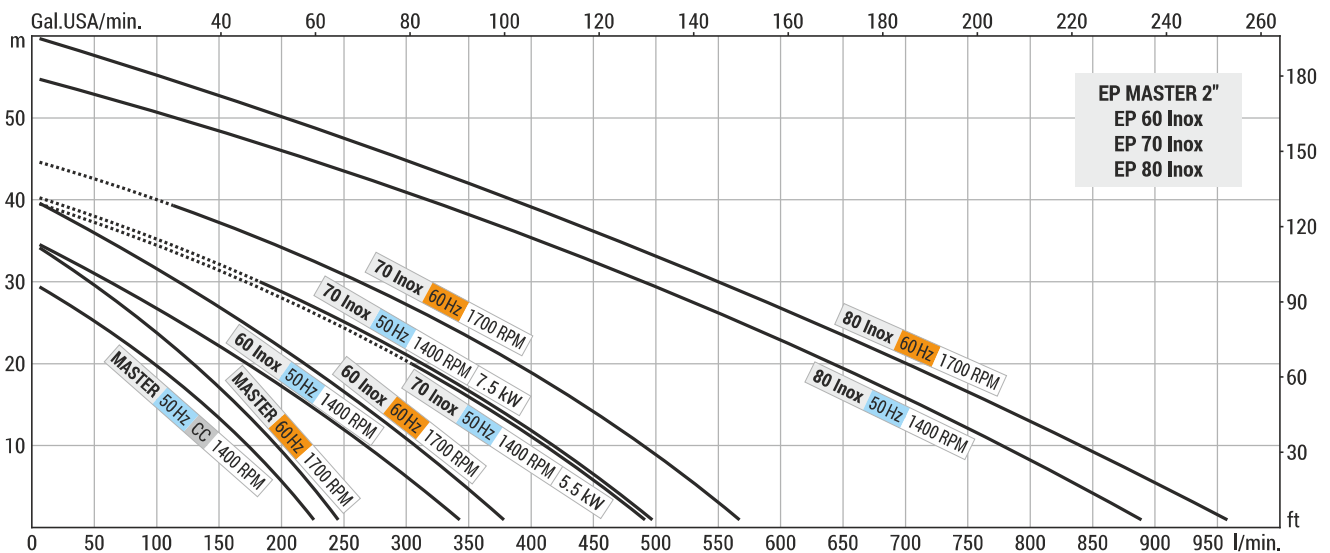
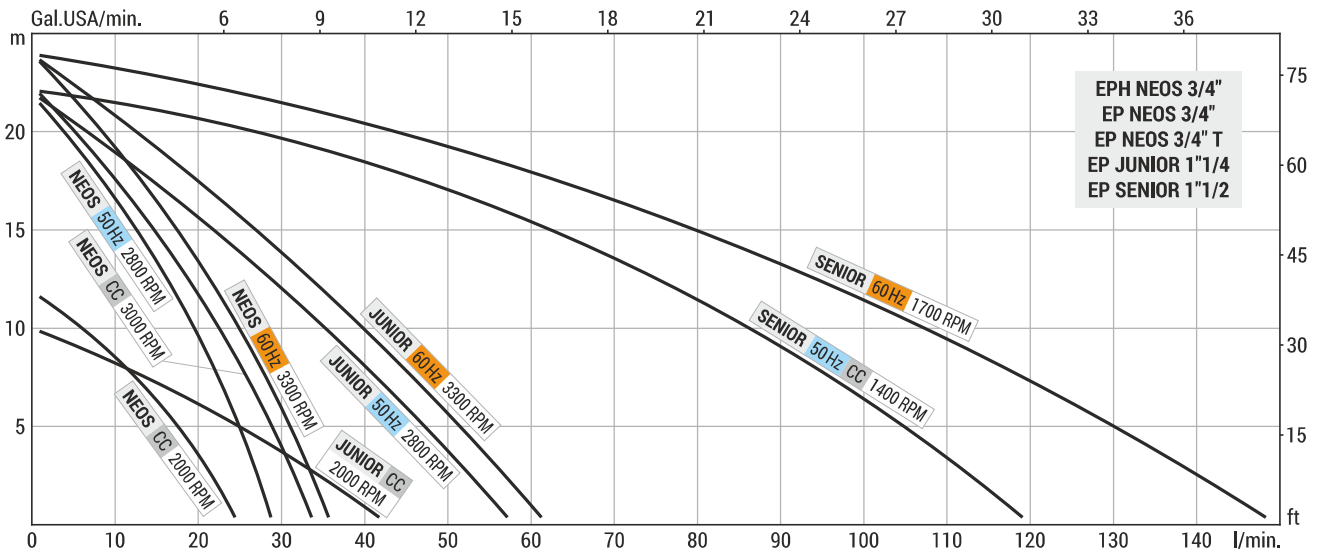

EPH NEOS 3/4"
EP NEOS 3/4"

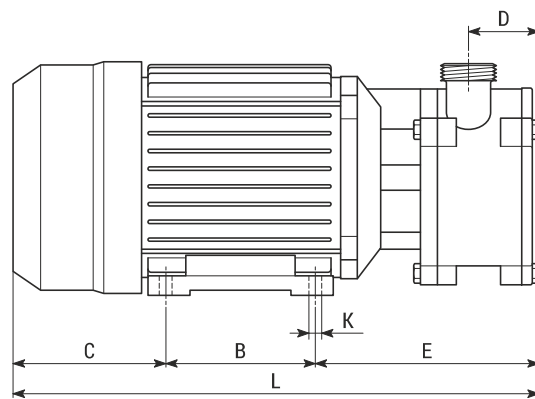
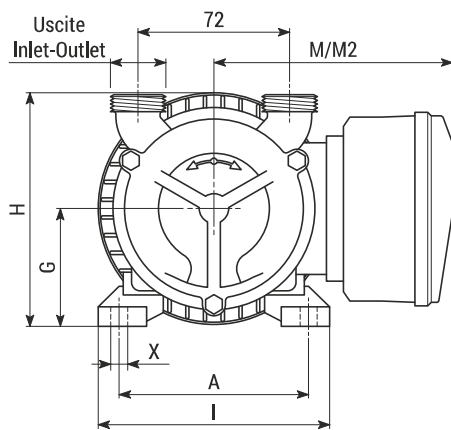

EP JUNIOR 1 1/4"

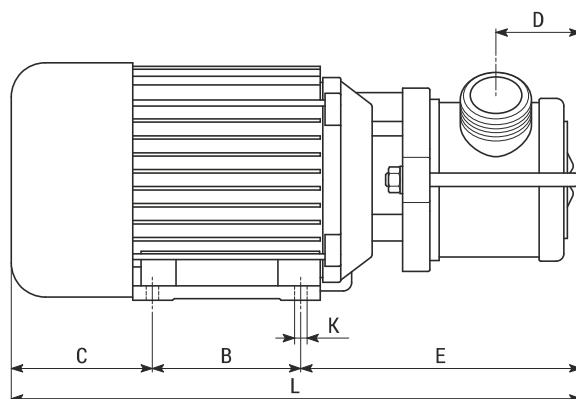
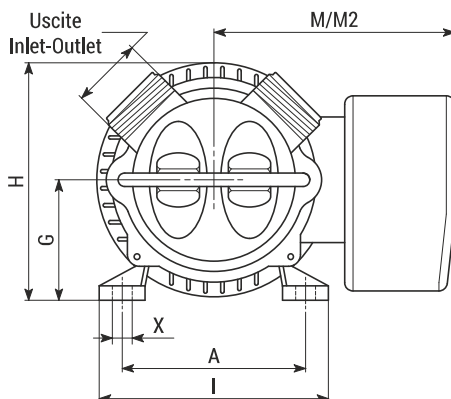

EP SENIOR 1 1/2"
EP MASTER 2"

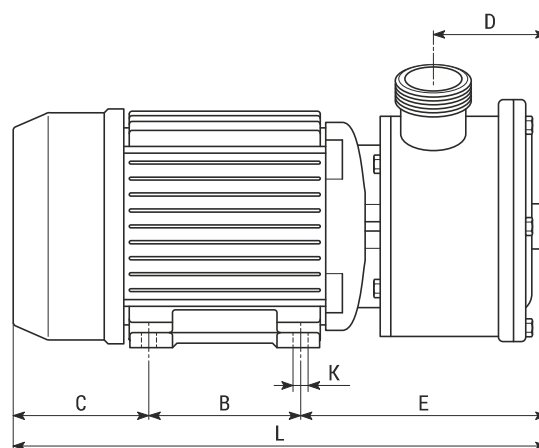
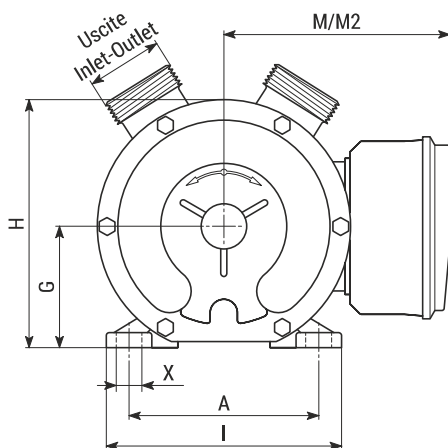

Tipo Type	Uscite Inlet-Outlet	Raccordi Pipe fittings	Motore Motor	Peso Weight	Dimensioni (mm) / Dimensions (mm)												
					A	B	C	D	E	G	H	I	K	L	M***	M2***	X
EPH NEOS 3/4"	BSP-M 3/4" *	Ø20 **	MF	5.5 kg	90	71	73	34	107	56	113	-	5.5	251	110	-	8
EP NEOS 3/4"	BSP-M 3/4" *	Ø20 **	CC	4.7 kg	100	80	100	34	115	71	123	-	7	295	-	110	12
			MF/TF	5.1 kg	90	71	73	34	107	56	113	-	5.5	251	135	100	8
EP JUNIOR 1 1/4"	BSP-M 1 1/4" *	Ø30 **	CC	9.3 kg	112	90	102	50	168	71	137	136	8	360	-	110	12
			MF/TF	9.6 kg	112	90	78	50	168	71	137	136	8	336	145	110	12
EP SENIOR 1 1/2"	BSP-M 1 1/2" *	Ø40 **	CC	19.9 kg	140	125	185	76	190	90	165	175	10	500	-	130	17.5
			MF/TF	17.6 kg	125	100	90	76	170	80	165	155	10	360	155	125	17.5
EP MASTER 2"	BSP-M 2" *	Ø50 **	CC	35.5 kg	140	125	137	94	185	90	193	175	10	447	-	-	17.5
			MF/TF	27.5 kg	140	125	100	94	215	90	193	175	10	440	160	130	17.5

* = Uscite standard, altre uscite disponibili p.30 / Standard inlet-outlet, different inlet-outlet are available see p.30

** = Raccordi in acciaio inox o nylon a richiesta / Stainless steel or nylon pipe fittings on request

M *** = interruttore/invertitore-portacondensatore / on-off reverse switch-capacitor box - M2 *** = morsettiera / terminal board connection

n.d. = Raccordi non disponibili / Pipe fittings not available

EP 60 Inox 2"

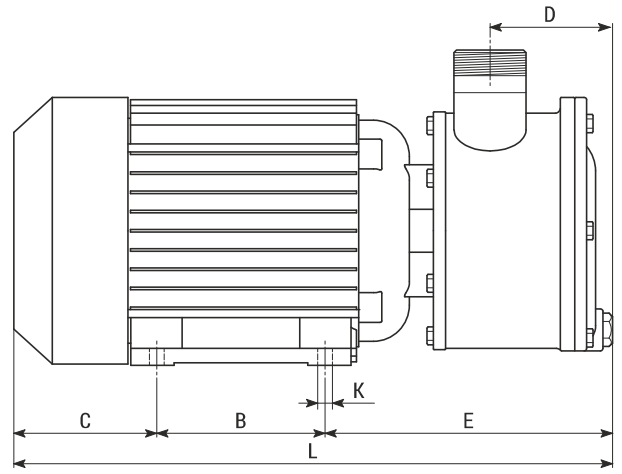
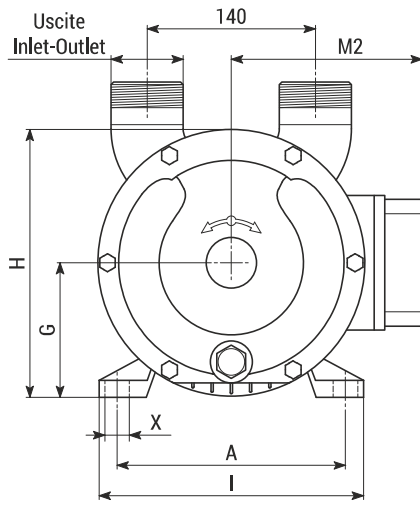

EP 70 Inox

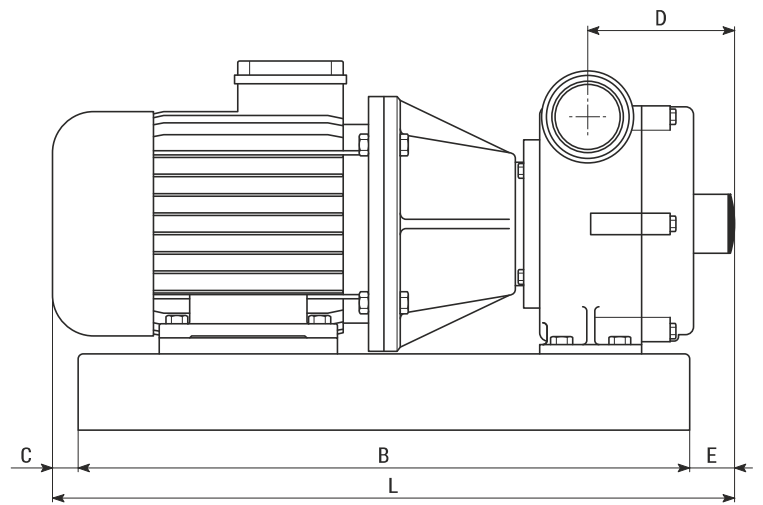
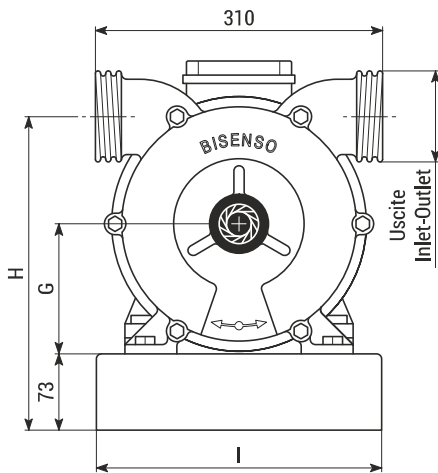

EP 80 Inox

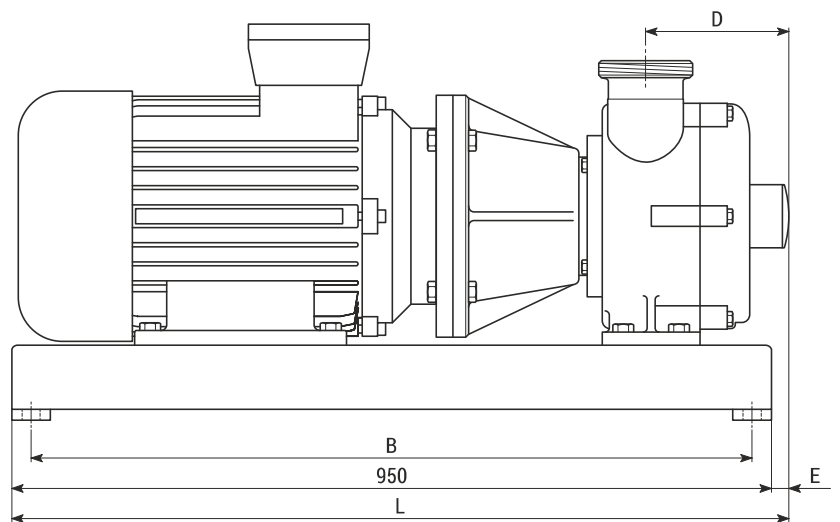
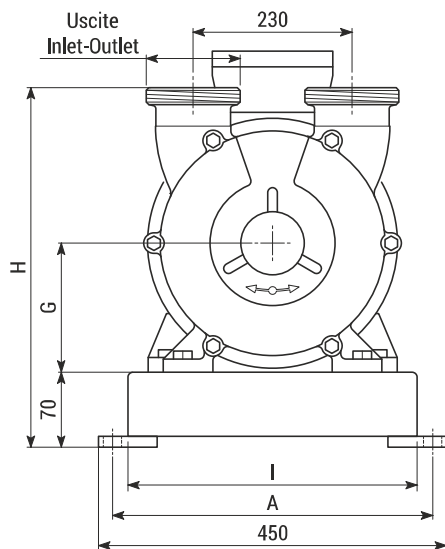

Tipo Type	Uscite Inlet-Outlet	Raccordi Pipe fittings	Motore Motor	Peso Weight	Dimensioni (mm) / Dimensions (mm)											
					A	B	C	D	E	G	H	I	K	L	M2 ***	X
EP 60 Inox 2"	BSP-M 2" *	Ø50 **	TF	42.0 kg	190	140	119	94	231	112	223	220	11	490	160	21
EP 70 Inox	DIN 65 *	n.d.	TF 5.5 kW	75.0 kg	-	600	43	144	47	128	306	270	-	690	-	-
			TF 7.5 kW	87.0 kg	-	600	110	144	80	132	310	270	-	790	-	-
EP 80 Inox	DIN 80 *	n.d.	TF 15 kW	216.0 kg	430	920	-	181	52	160	405	400	-	1002	-	-

* = Uscite standard, altre uscite disponibili p.30 / Standard inlet-outlet, different inlet-outlet are available see p.30

** = Raccordi in acciaio inox o nylon a richiesta / Stainless steel or nylon pipe fittings on request

M2 *** = morsettiera / terminal board connection

n.d. = Raccordi non disponibili / Pipe fittings not available