



Industrial Peristaltic Pumps

FMP-80 Data sheet



Capacity:	11,7 l/rev.
Connections:	DN-80
Max. Pressure:	8 bar
Rotor system:	Enlarged Rollers
Available hoses:	NR NBR EPDM HYPALON

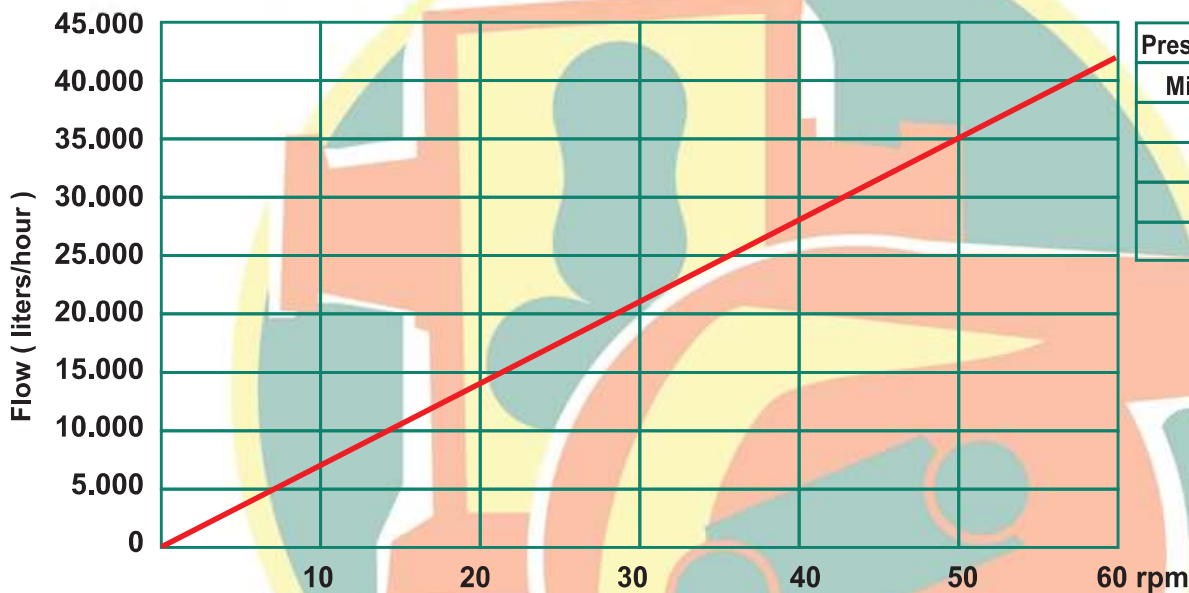

Pressure (bar)	Torque (Nm)
Minimum	860
2	900
4	1240
6	1680
8	2300

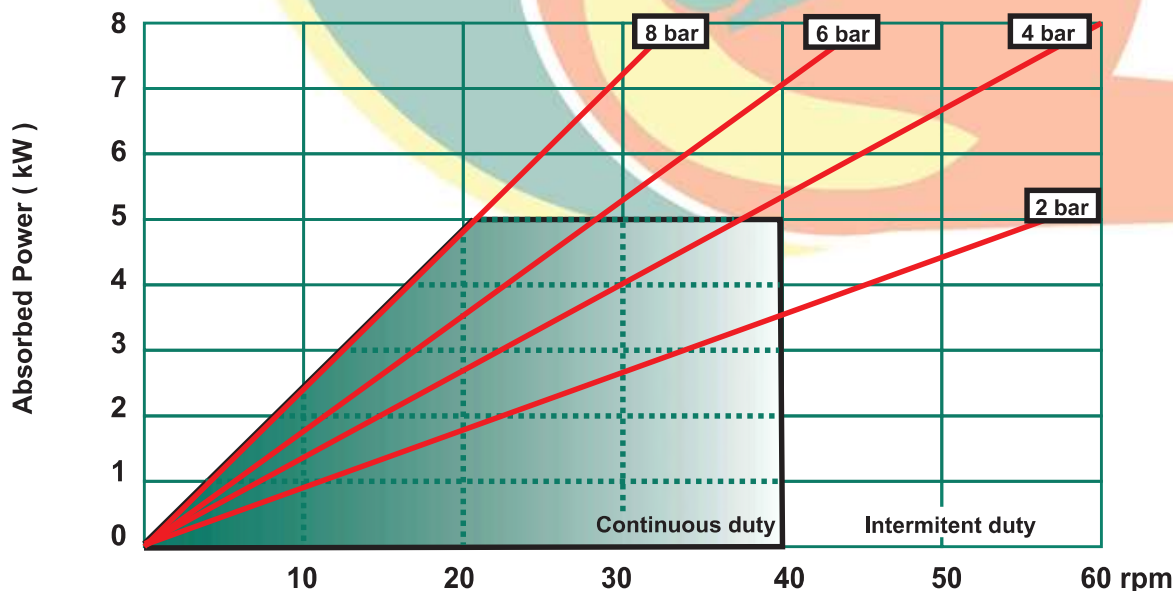

Description	Material	Surface treatment
Pump housing	Cast Iron EN-GJL-250	Liquid Painting, with two-component polyurethane paint Halar coated (Optional)
Front cover	PVC	--
Rotor	Nodular Cast Iron EN-GJL-400	Cataphoresis
Rollers	Steel F-114 + Polyurethane	--
Base plate	Steel F-111 Stainless Steel AISI-304 (Optional)	Polyester powder coated --
Connections	Stainless Steel AISI-316 Polypropylene (Optional) PVDF (Optional)	--

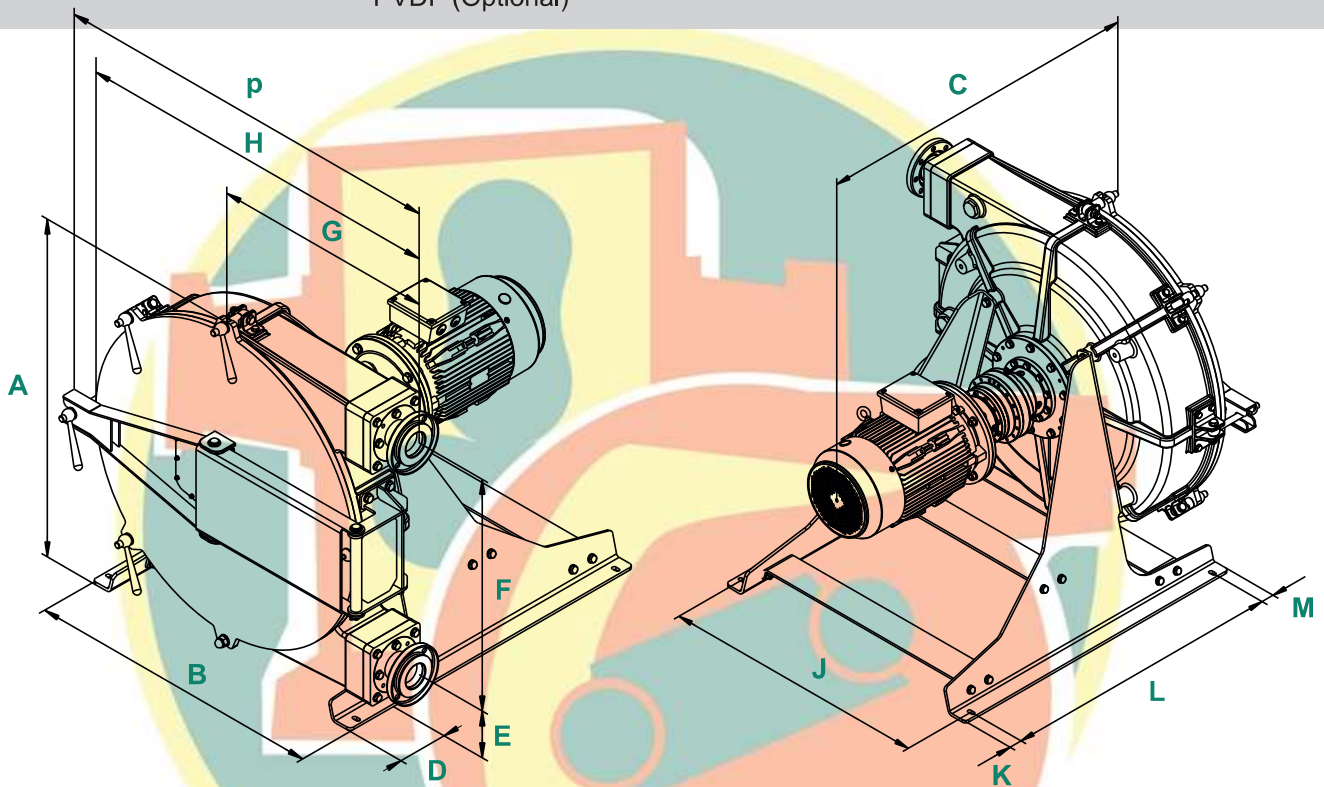

A	B	C	D	E	F	G	H	J	K	L	M	N	P	Connections
1225	1093	*	137	205	850	688	1235	1045	50	1100	275	50	1307	DIN DN80

* To confirm according type and power driver.



Bombas Boyser, S.L.
 c/ Miquel Martí i Pol, s/n - Pol. Ind. Pla de la Costa
 08182 Sant Feliu de Codines - Barcelona - Spain
 Tel. +34 93 844 77 78 info@boyser.com

www.boyser.com

