

CONSTRUCTION FEATURES IN DETAIL

TYPE F 716 PP AND F 716 PVDF

IN POLYPROPYLENE OR POLYVINYLIDENFLUORIDE SIZE 115 AND 135

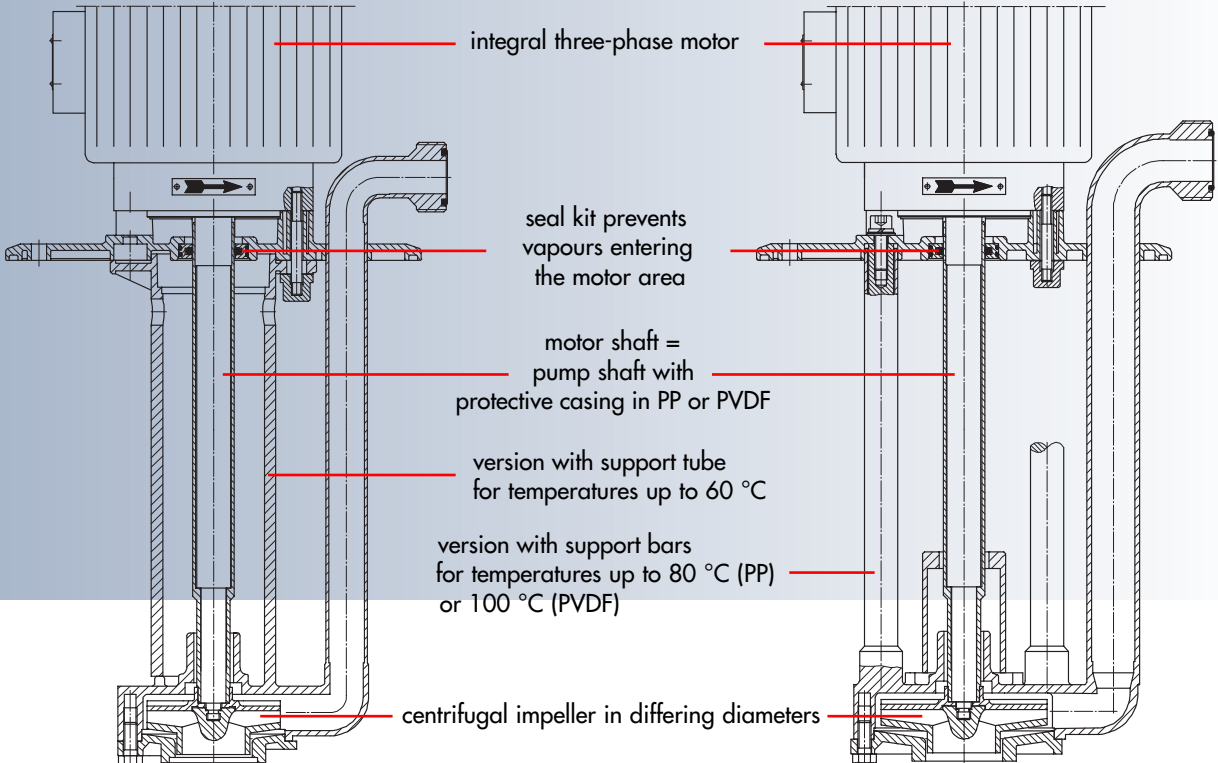

integral three-phase motor

seal kit prevents vapours entering the motor area

motor shaft = pump shaft with protective casing in PP or PVDF

version with support tube for temperatures up to 60 °C

version with support bars for temperatures up to 80 °C (PP) or 100 °C (PVDF)

centrifugal impeller in differing diameters

CONSTRUCTION FEATURES IN DETAIL

TYPE F 716 PP AND F 716 PVDF IN POLYPROPYLENE OR POLYVINYLIDENFLUORIDE SIZE 185 AND 230

