



METALLIC MAG-DRIVE REGENERATIVE TURBINE PUMPS



STANDARD

- Static shaft in HC 276.
- Chemical resistant PTFE/Carbon sleeve bearings standard.
- High torque magnetic coupling.
- Direct starting motors.

OPTIONAL

- DIN or ANSI flanges available.
- Explosion proof motor.
- Dry-running protection device.
- Baseplate.
- Available in ATEX version for zone 1 II2G and zone 2 II3G (pump mod. EM-T).

MAIN FEATURES

Mag drive regenerative turbine pumps series HTA are made of AISI 316 and are suitable for solvents, hydrocarbons, dangerous and inflammable liquids. Thanks to the innovative mag drive system, pumps model HTA reduce the risks of leakage and emissions and maintenance costs. The transmission of the motion occurs through magnetic joints without any mechanical seal. This design guarantees the maximum hermetic safety and efficiency. The pumped liquid has to be clean and without solids in suspension.

Pumps series HTA are also available in ATEX version for zone 1 and 2 (pump model EM-T).

- High head / low flow capability minimizes by-pass requirements.
- Materials available: AISI 316;
- Materials in contact with the liquid: casing and impeller: stainless steel AISI 316; o-ring EPDM/VITON; bushing: PTFEC; shaft: Hastelloy C276.
- Max flow 7 m³/h; max head 80 mlc.
- Max Temperature: 160°C.
- Pressure Rating NP 25 at 20°C.
- Impeller design handles up to 20% entrained gas. Ideal for pumping liquefied gas.

PERFORMANCE CURVES 50HZ - 2900 RPM

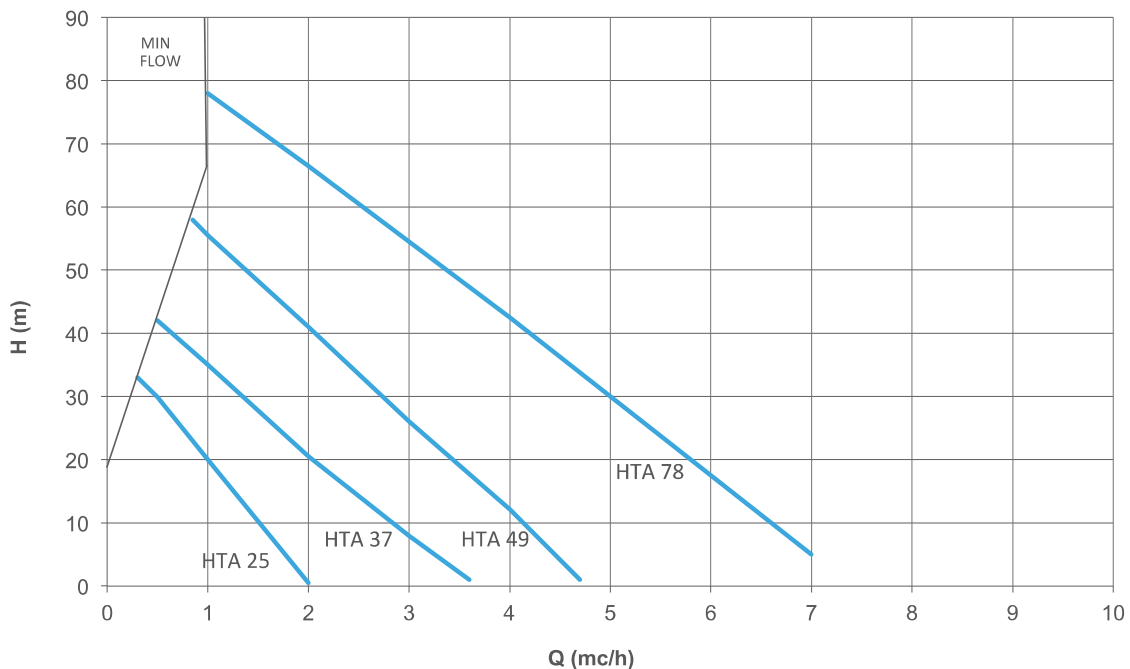

HTA TECHNICAL DATA

PUMP SIZE	MATERIAL	Q MAX		H MAX		SUCTION CONNECTION	DISCHARGE CONNECTION	PUMP WEIGHT (KG)	SUITABLE MOTOR POWER (Kw) - 2900 rpm	MOTOR FLANGE AND FRAME
		50HZ (M3/H)	60HZ (USGPM)	50HZ (MLC)	60HZ (FT)					
HTA 25	AISI316	2	10	32	140	3/4" FEMALE	3/4" FEMALE	10.3	1,1	80 - B3/B5
HTM 37	AISI316	3.5	19	43	180	3/4" FEMALE	3/4" FEMALE	10.3	1,1	80 - B3/B5
									2,2	90 - B3/B5
HTA 49	AISI316	4.7	25	58	235	1" FEMALE	1" FEMALE	18.7	2,2	90 - B5
									3	100 - B5
HTA 78	AISI316	7	36	76	320	1" FEMALE	1" FEMALE	19	3	100 - B5
									4	112 - B5

HTA 25-37 SS / EM-T 25-37 SS (ATEX VERSION) DIMENSIONS

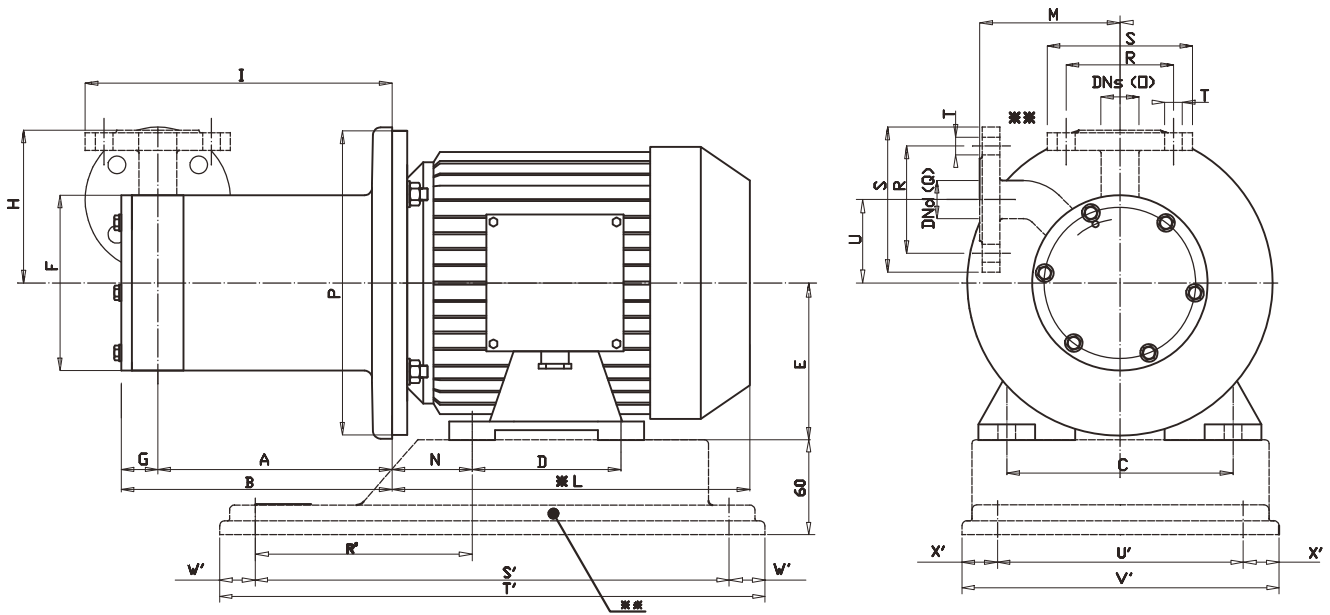

PUMP TYPE	FLANGES DIMENSIONS - mm -					
	R	S	T	DNs	DNd	
HTA 25-37	75	105	14	20	20	DN20 PN40

PUMP TYPE	MOTOR B3 - B5		DIMENSIONS - mm -														BASEPLATE DIMENSIONS - mm -								
	SIZE	KW	A	B	C	D	E	F	G	H	I	*L	M	N	O	P	Q	U	R'	S'	T'	U'	V'	W'	X'
HTA 25	80	1.1	167	192	125	100	80	123	25	100	218	232	98	50	3/4" G. FEMALE	200	3/4" G. FEMALE	61	120	302	350	157	205	24	24
HTA 37	80	1.1	167	192	125	100	80	123	25	100	220	232	98	50	3/4" G. FEMALE	200	3/4" G. FEMALE	61	120	302	350	157	205	24	24
	90	2.2	177	202	140	125	90				230	280		56					132						

* Different according to the motor supplier. ** OPTIONAL UPON REQUEST: Baseplate - Flanges.
NOTE: DIRECTION OF ROTATION IS COUNTER CLOCKWISE AS SEEN WHEN FACING THE MOTOR.
PUMPS AVAILABLE THREADED OR FLANGED.

HTA 49-78 SS / EM-T 49-78 SS (ATEX VERSION) DIMENSIONS

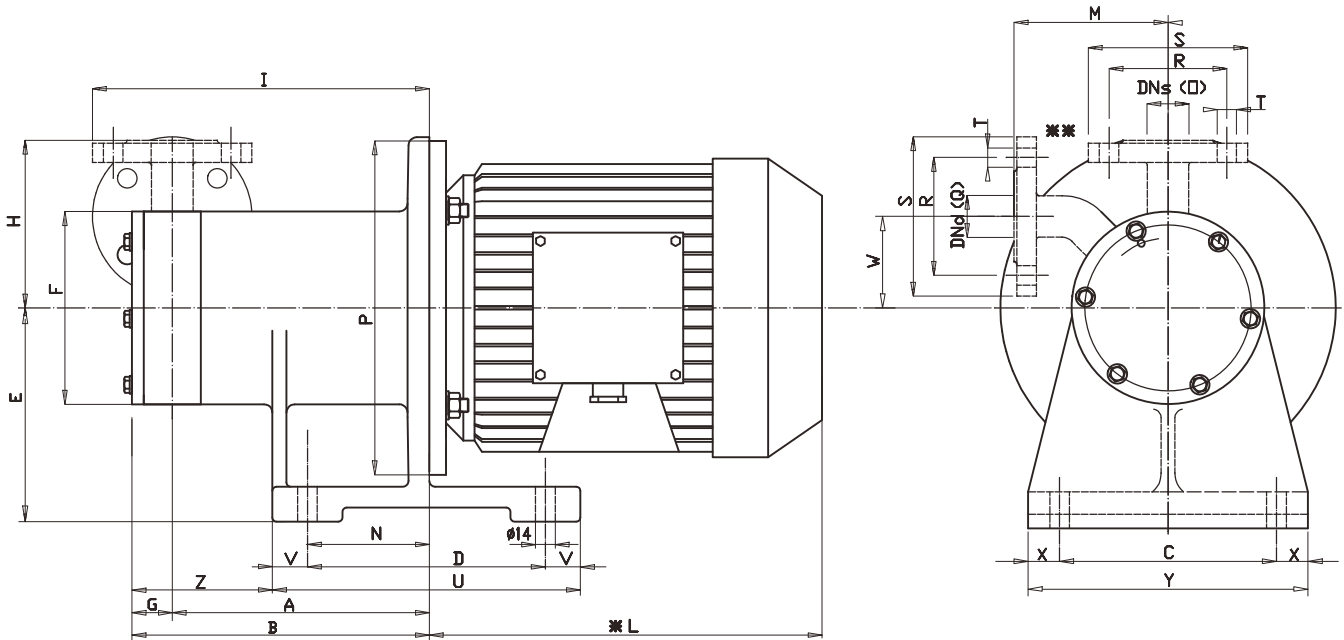

PUMP TYPE	FLANGES DIMENSIONS - mm -					
	R	S	T	DN _s	DN _d	
HTA 49-78	85	115	14	25	25	DN25 PN40

PUMP TYPE	MOTOR BS		DIMENSIONS - mm -																				
	SIZE	KW	A	B	C	D	E	F	G	H	I	*L	M	N	O	P	Q	U	V	W	X	Y	Z
HTA 49	90	2.2	185	215	155	170	150	139	30	121	253	280	111	109	1" G. FEMALE	200	1" G. FEMALE	220	25	62.5	22.5	200	91
	100	3	205	235							263	316		119		250							
HTA 78	100	3	205	235	155	170	150	158	30	133	263	316	133	119	1" G. FEMALE	250	1" G. FEMALE	220	25	85.5	22.5	200	91
	112	4									324												

* Different according to the motor supplier. ** OPTIONAL UPON REQUEST: Flanges.
NOTE: DIRECTION OF ROTATION IS COUNTER CLOCKWISE AS SEEN WHEN FACING THE MOTOR.
PUMPS AVAILABLE THREADED OR FLANGED.