

HTM 4-31 PP/PVDF



THERMOPLASTIC MAG-DRIVE CENTRIFUGAL PUMPS



STANDARD:

- Gas threaded In and Out connections.
- Direct starting motor.

OPTIONAL:

- Flanges available (DIN or ANSI).
- Dry-running protection.
- Baseplate.
- HTM pumps are available also for NEMA motors and with NPT connections.
- Available in ATEX version for zone 2 II3G (mod. EM-C PP/PVDF).

MAIN FEATURES

Mag drive centrifugal pumps series HTM PP/PVDF are made of thermoplastic materials (Polypropylene and PVDF) and are suitable for high corrosive liquids. Thanks to the innovative mag drive system, pumps model HTM PP/PVDF reduce the risks of leakage and emissions and the maintenance costs.

The transmission of the motion occurs through magnetic joints without any mechanical seal and this design guarantees the maximum safety and efficiency. The pumped liquid has to be clean and without solids in suspension.

- Materials available: PP / PVDF.
- Materials in contact with the liquid; casing and impeller: PP/PVDF; o-ring: EPDM (standard for PP pumps); VITON (standard for PVDF pumps); static shaft: Al203 99,7%; Bushing PTFEC.
- Max flow: 35 m³/h; Max head 24 mlc.
- Temperature: PP: max 70°C – PVDF: max 90°C.
- Max viscosity: 200 cSt.
- Pressure rating: NP 6 at 20°C.
- High torque magnetic coupling NdFeB standard.
- Suitable for high corrosive liquids.

PERFORMANCE CURVES 50HZ - 2900 RPM - SIZES FROM HTM 4 TO HTM 31

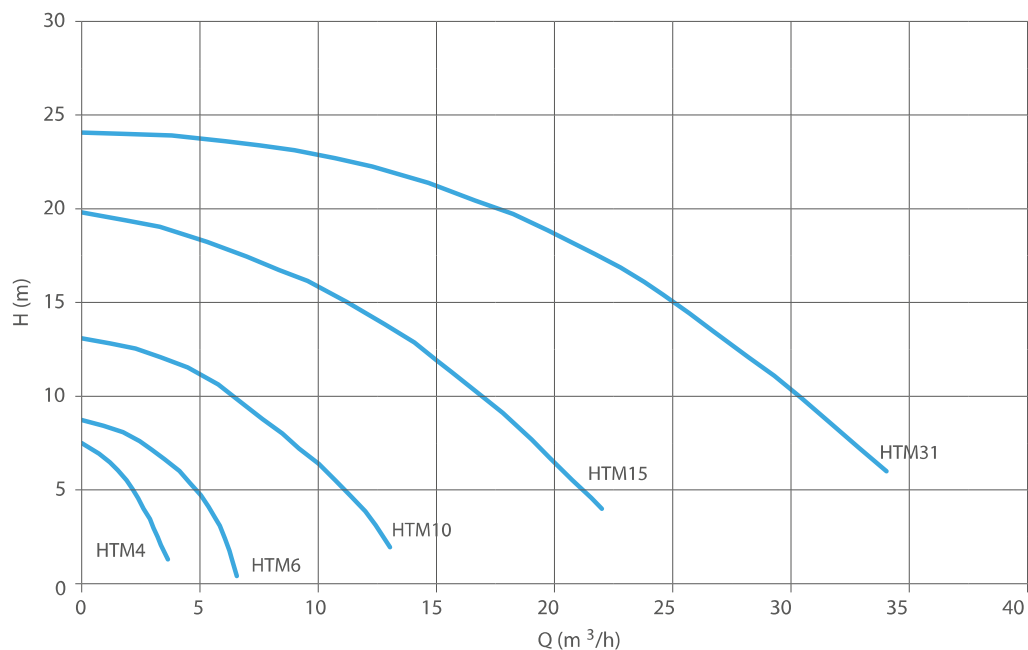

HTM PP/PVDF TECHNICAL DATA

PUMP SIZE	MATERIAL	Q MAX		H MAX		SUCTION CONNECTION	DISCHARGE CONNECTION	PUMP WEIGHT (kg)		SUITABLE MOTOR POWER (KW) 2900 rpm / FLANGE AND FRAME
		50HZ (m ³ /h)	60HZ (usgpm)	50HZ (mcl)	60HZ (ft)			PP	PVDF	
HTM 4	PP- PVDF	3,5	16	7	33	1" FEMALE	1/2" MALE	0.9	1	0,12 / 56 B - B3/B5
HTM 6	PP- PVDF	6,5	30	8,5	42	1" FEMALE	3/4" MALE	1.6	1.8	0,25 / 63 B - B3/B5
HTM 10	PP- PVDF	13	68	14	58	1 1/2" FEMALE	1" MALE	2.6	2.9	0,55 / 712B - B3/B5 • 1,1 / 80 B - B3/B5
HTM 15	PP- PVDF	23	125	20	90	2" MALE	1 1/2" MALE	5.8	6.6	1,1 / 80 B - B3/B5 • 1,5 / 90 S - B3/B5 • 2,2/90L - B3/B5
HTM 31	PP- PVDF	35	185	24	115	2 1/2" MALE	2" MALE	8.0	8.9	2,2 / 90 L - B3/B5 • 3 / 100 L - B3/B5 • 4 / 112 M - B3/B5

HTM 4-6-10 PP/PVDF DIMENSIONS

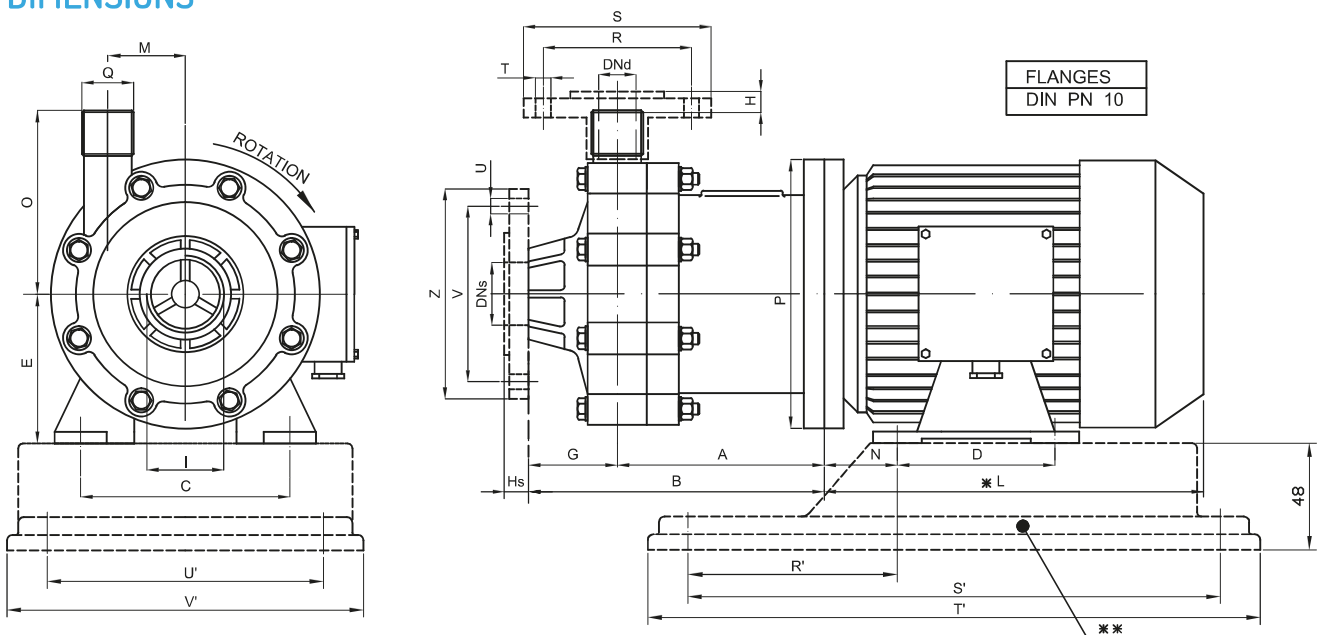

PUMP TYPE	FLANGES DIMENSIONS - mm -							
	R	S	T	U	V	Z	DN _s	DN _d
HTM 4	-	-	-	-	-	-	-	-
HTM 6	75	105	14	14	85	115	25	20
HTM 10	85	115	14	18	110	150	40	25

PUMP TYPE	MOTOR FLANGE B3 - B5	KW	DIMENSIONS - mm -														BASEPLATE DIMENSIONS - mm -					
			A	B	C	D	E	H _s	G	H	I	L*	M	N	O	P	Q	R'	S'	T'	U'	V'
HTM 4	56 B	0,12	76	115	90	71	56	-	39	-	1" FEMALE	176	34	36	80	120	1/2" MALE	94	244	280	130	160
HTM 6	63 B	0,25	85	143	100	80	63	22	59	6	1" FEMALE	191	45	40	98	140	3/4" MALE	102	244	280	130	160
HTM 10	712B	0,55	112	180	112	90	71	34	70	5	1 1/2" FEMALE	215	45	45	100	160	1" MALE	112	244	280	130	160
HTM 10	80B	1,1	122	190	125	100	80	34	70	5	1 1/2" FEMALE	232	45	50	100	200	1" MALE	120	302	350	157	205

* Different according to the manufacturer. ** OPTIONAL UPON REQUEST: Baseplate - Flanges.
 NOTE: DIRECTION OF ROTATION IS COUNTER CLOCKWISE AS SEEN WHEN FACING THE MOTOR.
 PUMPS AVAILABLE THREADED OR FLANGED.

HTM 15-31 PP/PVDF DIMENSIONS

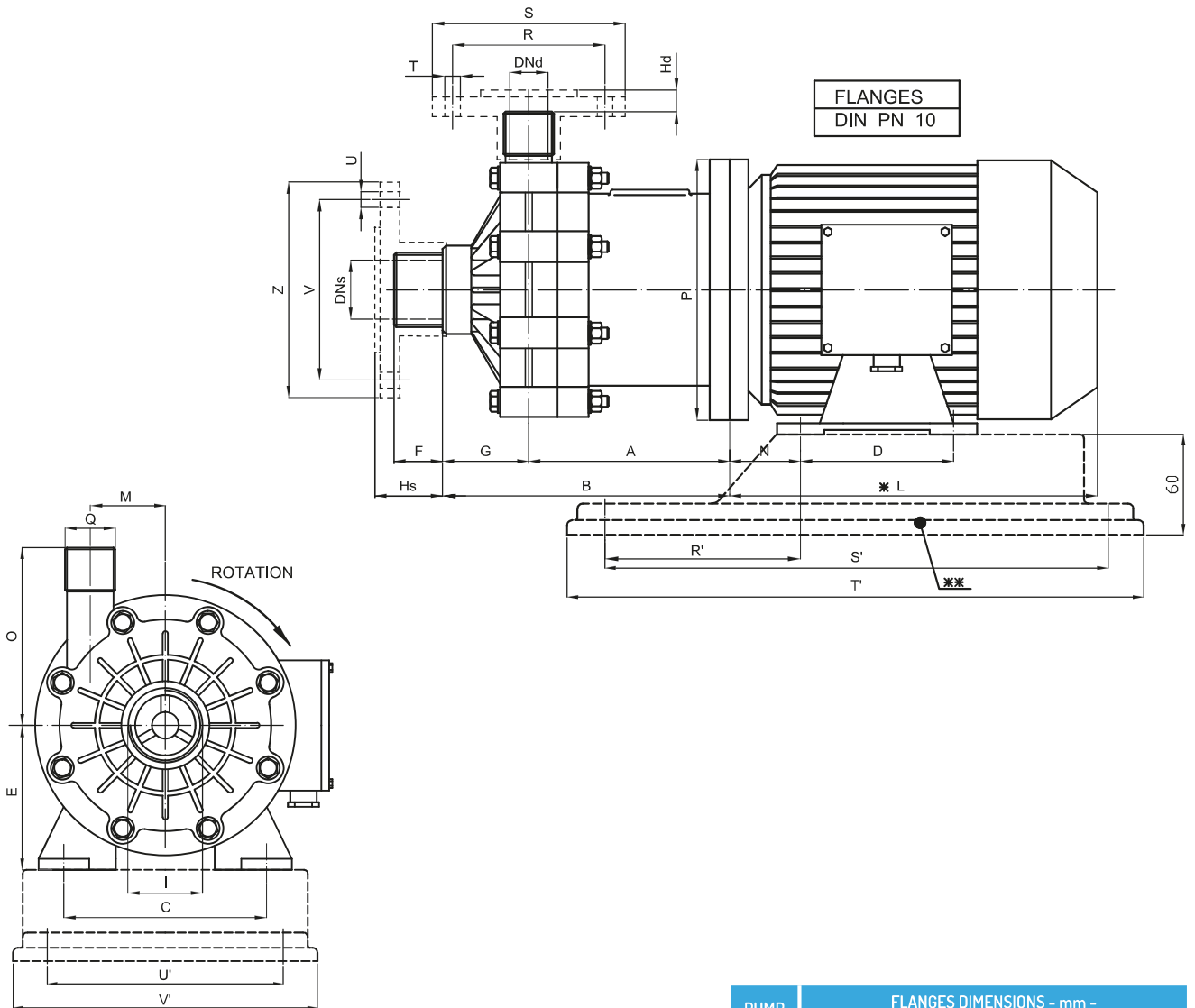

PUMP TYPE	FLANGES DIMENSIONS - mm -							
	R	S	T	U	V	Z	DNs	DNd
HTM 15	110	153	18	18	125	168	50	40
HTM 31	125	168	18	18	145	188	65	50

PUMP TYPE	MOTOR FLANGE B3 - B5	KW	DIMENSIONS - mm -														BASEPLATE DIMENSIONS - mm -						
			A	B	C	D	E	F	G	Hs	Hd	I	L*	M	N	O	P	Q	R'	S'	T'	U'	V'
HTM 15	80 B	1,1	150	230	125	100	80	28	52	42	13	2" MALE	232	66	50	135	200	1-1/2" MALE	120	302	350	157	205
HTM 15	90 S	1,5	160	240	140	100	90	28	52	42	13	2" MALE	256	66	56	135	200	1-1/2" MALE	132	302	350	157	205
HTM 31	90 L	2,2	184	245	140	125	90	30	61	44	13	2 1/2" MALE	280	66	56	140	200	2" MALE	132	302	350	157	205
HTM 31	100 L	3	203	264	160	140	100	30	61	44	13	2 1/2" MALE	315	66	63	140	250	2" MALE	140	352	400	202	250
HTM 31	112 M	4	203	264	190	140	112	30	61	44	13	2 1/2" MALE	325	66	70	140	250	2" MALE	140	352	400	202	250

* Different according to the manufacturer. ** OPTIONAL UPON REQUEST: Baseplate - Flanges.
NOTE: DIRECTION OF ROTATION IS COUNTER CLOCKWISE AS SEEN WHEN FACING THE MOTOR.
PUMPS AVAILABLE THREADED OR FLANGED.

HTM 40-100 PP/PVDF

NEW



THERMOPLASTIC MAG-DRIVE CENTRIFUGAL PUMPS



STANDARD:

- Gas threaded In and Out connections.
- Direct starting motor.
- HTM 80-100: standard pumps supplied with DIN flanges.

OPTIONAL:

- Flanges available (DIN or ANSI).
- Dry-running protection device.
- Baseplate available for HTM 40.
- HTM 40-50 are available for NEMA motors and with NPT connections.
- Available in ATEX version for zone 2 II3G (mod. EM-C PP/PVDF).

MAIN FEATURES

Mag drive centrifugal pumps series HTM PP/PVDF are made of thermoplastic materials (Polypropylene and PVDF) and are suitable for high corrosive liquids. Thanks to the innovative mag drive system, pumps model HTM PP/PVDF reduce the risks of leakage and emissions and the maintenance costs.

The transmission of the motion occurs through magnetic joints without any mechanical seal and this design guarantees the maximum safety and efficiency. The pumped liquid has to be clean and without solids in suspension.

- Materials available: PP / PVDF.
- Materials in contact with the liquid; casing and impeller: PP/PVDF; o-ring: EPDM (standard for PP pumps); VITON (standard for PVDF pumps); static shaft: Al203 99,7 %; Bushing PTFEC.
- Max flow: 130 m³/h; Max head 48 m.
- Temperature: PP: max 70°C - PVDF: max 90°C.
- Max viscosity: 200 cSt.
- Pressure rating: NP 6 at 20°C.
- High torque magnetic coupling NdFeB standard.
- Suitable for high corrosive liquids.

PERFORMANCE CURVES 50HZ - 2900 RPM - SIZES FROM HTM 40 TO HTM 100

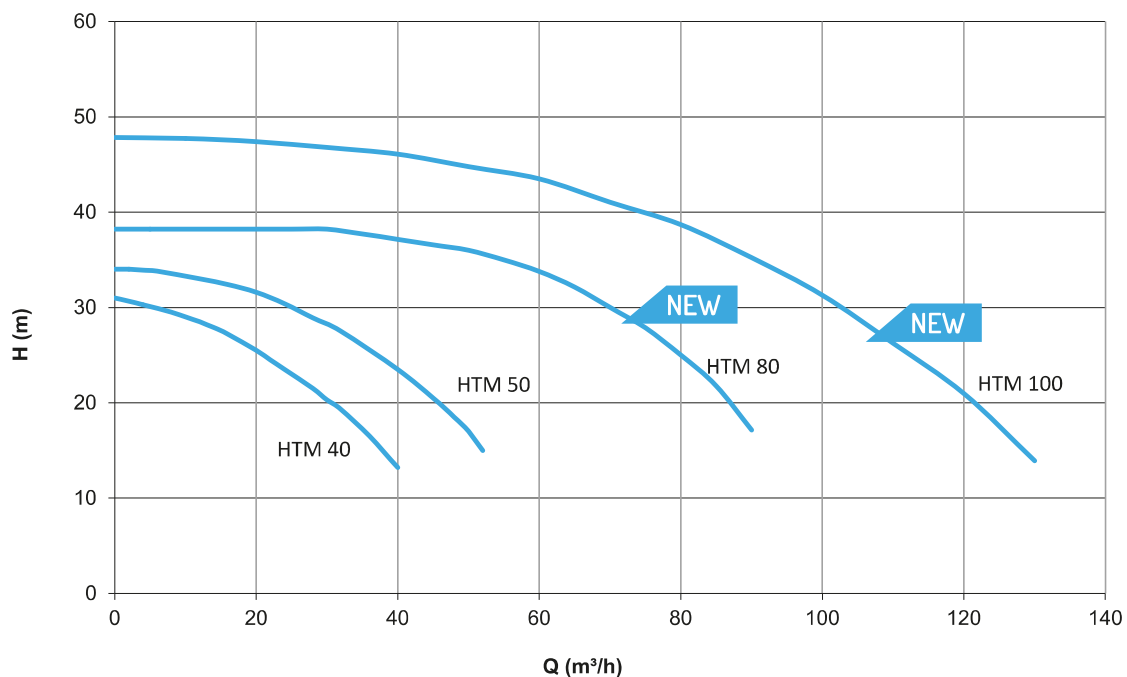

HTM PP/PVDF TECHNICAL DATA

PUMP SIZE	MATERIAL	Q MAX		H MAX		SUCTION CONNECTION	DISCHARGE CONNECTION	PUMP WEIGHT (kg)		SUITABLE MOTOR POWER (Kw) 2900 rpm / FLANGE AND FRAME
		50HZ (m³/h)	60HZ (usgpm)	50HZ (mcl)	60HZ (ft)			PP	PVDF	
HTM 40	PP- PVDF	42	215	31	150	3" MALE	2 1/2" MALE	19.7	21.3	3/100 L - B3/B5 • 4/112M - B3/B5
HTM 50	PP- PVDF	43	220	33	160	3" MALE	2 1/2" MALE	32.2	35	5.5 / 132 S2A - B5 • 7.5 / 132 S2B - B5
HTM 80	PP- PVDF	90	352	38	123	DIN 80	DIN 65	42	44	7.5 / 132 S2 - B5 • 11 / 160 M2A - B5 15 / 160 M2B - B5 • 18.5 / 160 L2 - B5
HTM 100	PP- PVDF	130	528	48	148	DIN 100	DIN 80	40	45	11 / 160 M2A - B5 • 15 / 160 M2B - B5 18.5 / 160 L2 - B5 • 22 / 180 M2 - B5

HTM 40 PP/PVDF DIMENSIONS

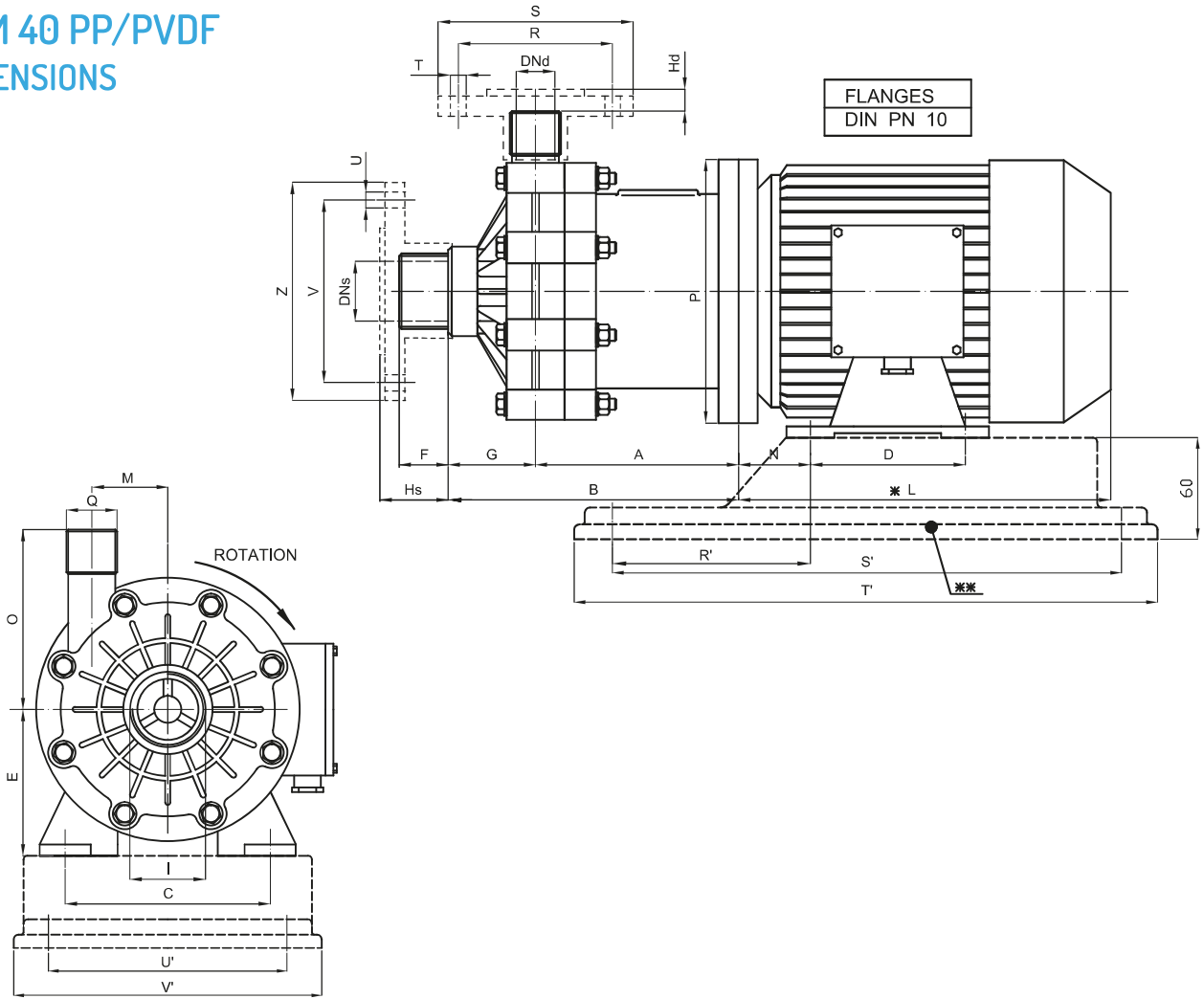

PUMP TYPE	MOTOR FLANGE B3 - B5	KW	DIMENSIONS - mm -															BASEPLATE DIMENSIONS - mm -					
			A	B	C	D	E	F	G	Hs	Hd	I	L*	M	N	O	P	Q	R'	S'	T'	U'	V'
HTM 40	100 L	3	228	320	160	140	100	40	52	50	10	3" MALE	315	82.5	63	170	250	2 1/2" MALE	140	352	400	202	250
HTM 40	112 M	4	228	320	190	140	112	40	52	50	10	3" MALE	325	82.5	70	170	250	2 1/2" MALE	156	352	400	202	250

PUMP TYPE	FLANGES DIMENSIONS - mm -							
	R	S	T	U	V	Z	DNs	DNd
HTM 40	145	188	18	18	160	203	80	65

* Different according to the manufacturer.
 OPTIONAL UPON REQUEST: Flanges and baseplate.
 NOTE: DIRECTION OF ROTATION IS COUNTER CLOCKWISE AS SEEN WHEN FACING THE MOTOR.
 PUMPS AVAILABLE THREADED OR FLANGED.

HTM 50 PP/PVDF DIMENSIONS

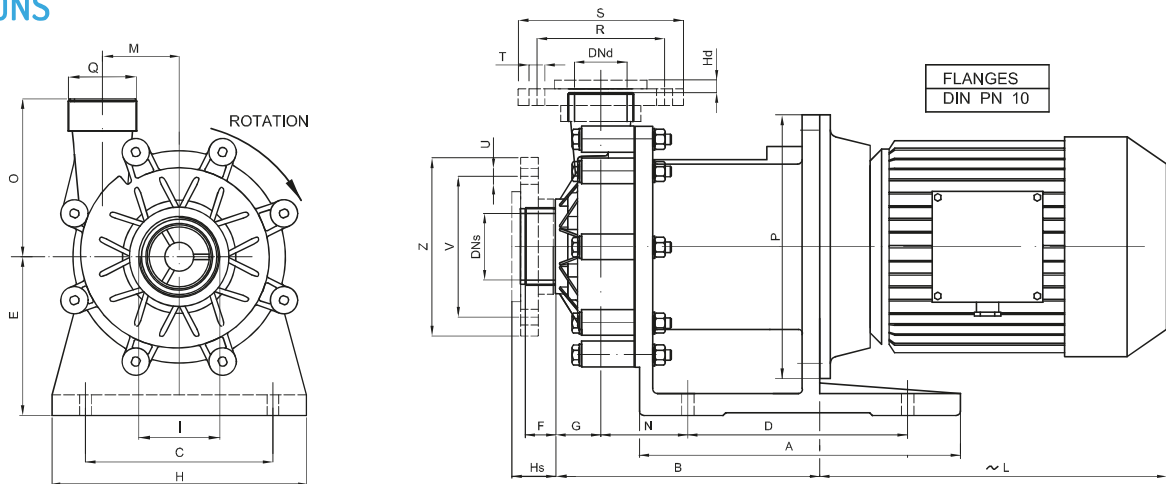

PUMP TYPE	MOTOR FLANGE B3 - B5	KW	DIMENSIONS - mm -																
			A	B	C	D	E	F	G	H	Hs	Hd	I	-L	M	N	O	P	Q
HTM 50	132 S2A	5,5	365	339	216	250	192	40	52	274	50	10	3"	383	82,5	98	170	300	2 1/2"
HTM 50	132 S2B	7,5	365	339	216	250	192	40	52	274	50	10	3"	421	82,5	98	170	300	2 1/2"

PUMP TYPE	FLANGES DIMENSIONS - mm -							
	R	S	T	U	V	Z	DNs	DNd
HTM 50	145	188	18	18	160	203	80	65

HTM 80-100PP/PVDF DIMENSIONS

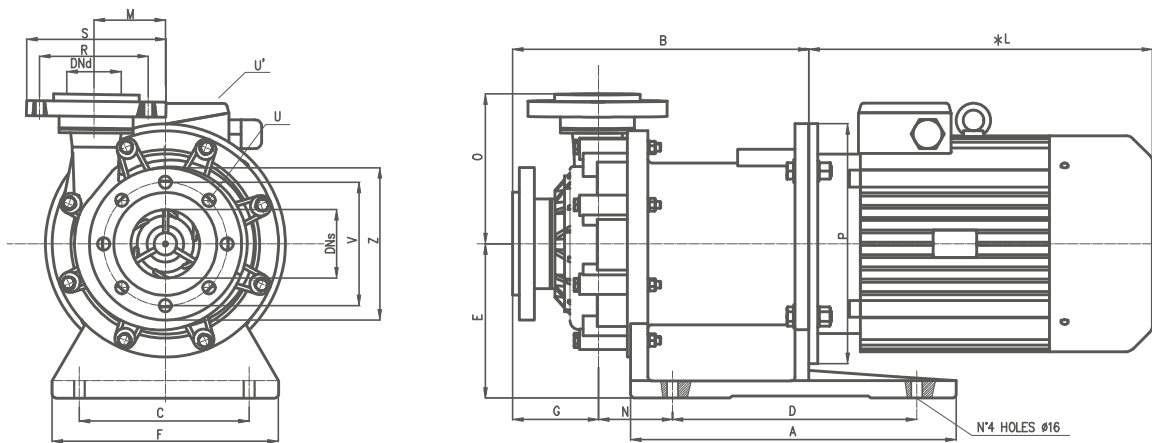

PUMP TYPE	MOTOR FLANGE B5	KW	DIMENSIONS - mm -											
			A	B	C	D	E	F	G	*L	M	N	O	P
HTM 80	G 132S2	7,5	475	433	250	360	225	330	126	421	103	104	215	300
HTM 80	G 160M2A	11	475	433	250	360	225	330	126	510	103	104	215	350
HTM 80	G 160M2B	15	475	433	250	360	225	330	126	510	103	104	215	350
HTM 80	G 160L2	18,5	475	433	250	360	225	330	126	554	103	104	215	350
HTM 100	G 160M2A	11	475	435	250	360	225	330	124	510	103	104	217	350
HTM 100	G 160M2B	15	475	435	250	360	225	330	124	510	103	104	217	350
HTM 100	G 160L2	18,5	475	435	250	360	225	330	124	554	103	104	217	350
HTM 100	G 180M2	22	475	435	250	360	225	330	124	595	103	104	217	350

PUMP TYPE	FLANGES DIMENSIONS - mm -							
	R	S	U	U*	V	Z	DNs	DNd
HTM 80	145	188	n° 8 holes Ø18	n° 4 holes Ø18	160	200	80	65
HTM 100	160	200	n° 8 holes Ø18	n° 8 holes Ø18	180	220	100	80

* Different according to the manufacturer.
NOTE: DIRECTION OF ROTATION IS COUNTER CLOCKWISE AS SEEN WHEN FACING THE MOTOR.

* HTM 50, OPTIONAL UPON REQUEST: Flanges.
* HTM 80-100: standard pumps supplied with DIN flanges.