



METALLIC ROTARY VANE MAG-DRIVE PUMPS DRY SELF-PRIMING



MAIN FEATURES

Rotary vane mag drive pumps series HTP are made of AISI 316 and are suitable for hydrocarbons, solvents, heat transfer oils, refrigerants, cryogenics and radioactive liquids. Thanks to the innovative mag drive system, pumps model HTP reduce the risks of leakage and emissions and the maintenance costs. HTP pumps are useful for low flow and high head applications such as Pilot Plants, Sampling and Flushing of mechanical seals. Especially designed for thin non-lubricating liquids and/or high differential pressure.

Pumps series HTP are also available in ATEX version for zone 1 and 2 (pump model EM-P).

STANDARD

- High torque magnetic coupling.
- Direct starting motor.

OPTIONAL

- Flanges available (DIN or ANSI).
- Dry-running protection device.
- Baseplate.
- Explosion proof motor.
- Available in ATEX version for zone 1 II3G and zone 2 II3G (pump mod. EM-P).

- Materials available: AISI 316.
- Materials in contact with the liquid:
 - pump body, end cover and rotor: AISI 316;
 - o-ring: EPDM/VITON; carbon graphite stator.
- Max flow: 2100 l/h. Max pressure 13 bar.
- Temperature range: from -70°C to $+200^{\circ}\text{C}$.
- Max viscosity: 2000 cPs.
- System Pressure 25 bar at 20°C .

PERFORMANCE CURVES 50HZ - 1450 RPM

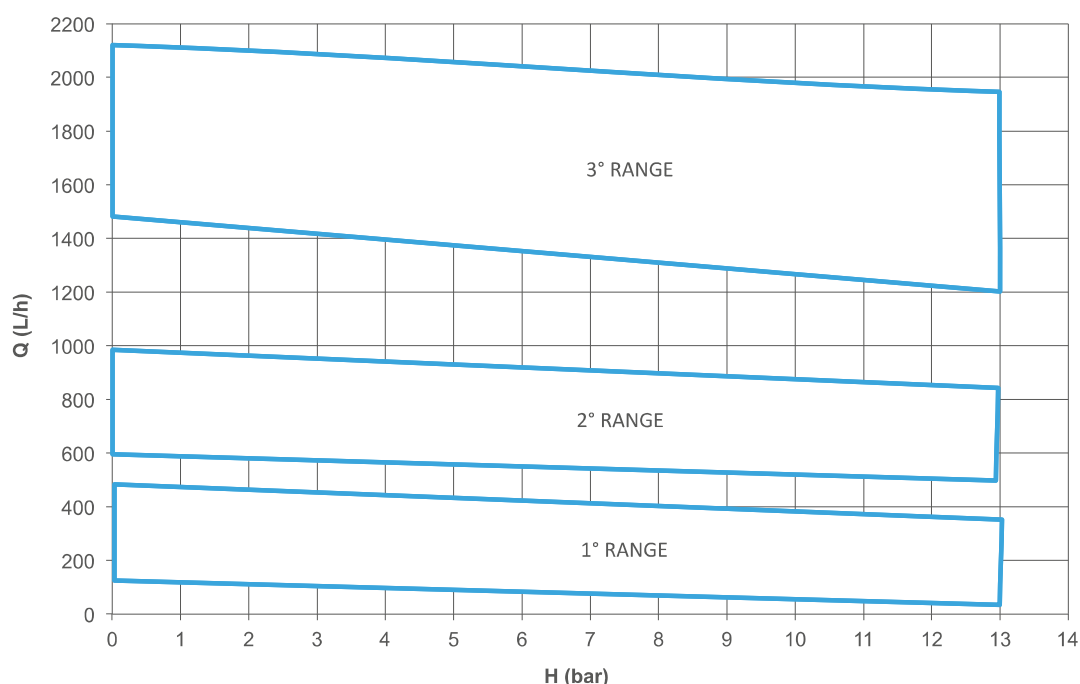

HTP TECHNICAL DATA

PUMP SIZE	MATERIAL	Q MAX		H MAX		SUCTION CONNECTION	DISCHARGE CONNECTION	PUMP WEIGHT (KG)	SUITABLE MOTOR POWER (KW) - 1450 rpm	MOTOR FLANGE AND FRAME
		50HZ (l/h)	60HZ (usgpm)	50HZ (bar)	60HZ (PSI)					
HTP 100 1'R	AISI316	120	0.66	13	188	3/8" FEMALE	3/8" FEMALE	5	0,37	71 - B3/B5
HTP 200 1'R	AISI316	250	1.4	13	188	3/8" FEMALE	3/8" FEMALE	5	0,37	71 - B3/B5
HTP 300 1'R	AISI316	350	1.9	13	188	3/8" FEMALE	3/8" FEMALE	5	0,37	71 - B3/B5
HTP 400 1'R	AISI316	450	2.3	13	188	3/8" FEMALE	3/8" FEMALE	5	0,37	71 - B3/B5
HTP 600 2'R	AISI316	600	3.3	13	188	1/2" FEMALE	1/2" FEMALE	8.3	0,75	80 - B3/B5
HTP 800 2'R	AISI316	800	4.3	13	188	1/2" FEMALE	1/2" FEMALE	8.3	0,75	80 - B3/B5
HTP 1000 2'R	AISI316	980	5	13	188	1/2" FEMALE	1/2" FEMALE	8.3	1,5	90 - B3/B5
HTP 1500 3'R	AISI316	1500	8	13	188	3/4" FEMALE	3/4" FEMALE	19.5	1,5	90 - B5
HTP 2000 3'R	AISI316	2100	11.1	13	188	3/4" FEMALE	3/4" FEMALE	19.5	2,2	100 - B5
									3	100 - B5
									4	112 - B5

HTP 1°-2° RANGE / EM-P 1°- 2° RANGE (ATEX VERSION) DIMENSIONS

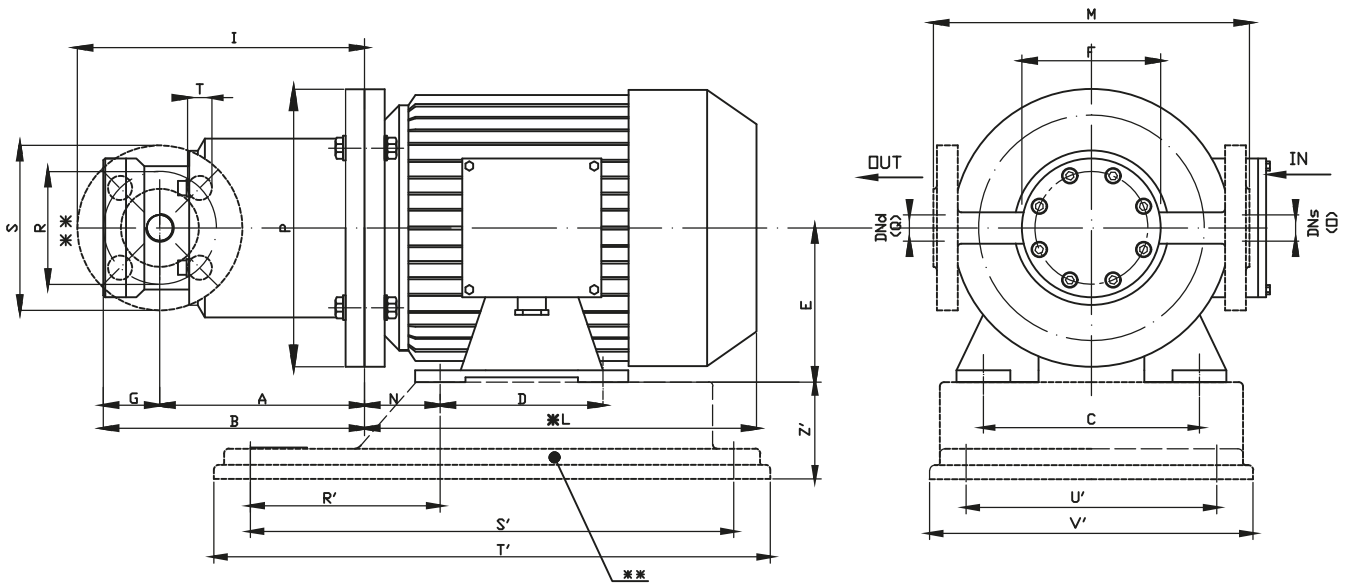

PUMP TYPE	FLANGES DIMENSIONS - mm -					
	R	S	T	DNs	DNd	
HTP 1° RANGE	65	95	14	15	15	DN15 PN40
HTP 2° RANGE	75	105	14	20	20	DN20 PN40

PUMP TYPE	MOTOR FLANGE B3 - B5	Kw	DIMENSIONS - mm -													BASEPLATE DIMENSIONS - mm -						
			A	B	C	D	E	F	G	I	*L	M	N	O	P	Q	R'	S'	T'	U'	V'	Z'
HTP 1° RANGE	71	0,37	127	160	112	90	71	80	33	175	215	182	45	3/8"G.	160	3/8"G.	112	244	280	130	160	48
HTP 2° RANGE	80	0,75	166	204	125	100	80				232		50				120					
	90 S	1,5	176	214	140	125	90	123	38	218	280	194	56	1/2"G.	200	1/2"G.	132	302	350	157	205	60

* Different according to the motor supplier. ** OPTIONAL UPON REQUEST: Baseplate - Flanges.
NOTE: DIRECTION OF ROTATION IS COUNTER CLOCKWISE AS SEEN WHEN FACING THE MOTOR.
PUMPS AVAILABLE THREADED OR FLANGED.

HTP 3° RANGE / EM-P 3° RANGE (ATEX VERSION) DIMENSIONS

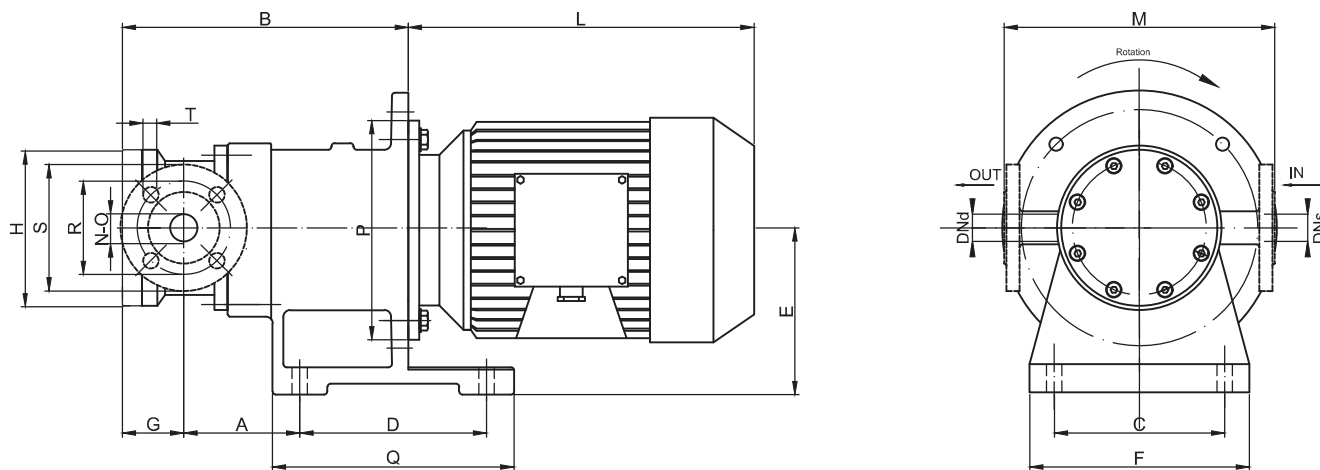

PUMP TYPE	FLANGES DIMENSIONS - mm -					
	R	S	T	DNs	DNd	
HTP 3° RANGE	85	115	14	25	25	DN25 PN40

PUMP TYPE	MOTOR B5 4P		DIMENSIONS - mm -													
	SIZE	KW	A	B	C	D	E	F	G	H	*L	M	N	O	P	Q
HTP 3° RANGE	90L	1.5	106	260	155	170	150	200	56	142	280	246	3/4" G.	3/4" G.	200	220
	100L	2.2 / 3	106	280	155	170	150	200	56	142	316	246	3/4" G.	3/4" G.	250	220
	112M	4	106	280	155	170	150	200	56	142	334	246	3/4" G.	3/4" G.	250	220

* Different according to the motor supplier. ** OPTIONAL UPON REQUEST: Flanges.
NOTE: DIRECTION OF ROTATION IS COUNTER CLOCKWISE AS SEEN WHEN FACING THE MOTOR.
PUMPS AVAILABLE THREADED OR FLANGED.