

Technical data sheet

JUNIORFLUX



More than just pumps

JUNIORFLUX



Special features:

- ▶ Motor and pump tightly connected
- ▶ Two pump types available - with mechanical seal or sealless
- ▶ With mains connection
- ▶ Internal ventilated commutator motor
- ▶ Motor double insulated - protection class II
- ▶ Two step speed adjustment
- ▶ With overload cut-out switch
- ▶ 230 Volt version VDE-GS approved
- ▶ Ergonomic design handle - one-handed operation
- ▶ Holding hook for medium hose

Commutator motor F 310

Motor type	Storage of motor	Speed control	Allowed ambient temperature in operation [°C]	Allowed ambient temperature on storage [°C]	Max. viscosity [mPas]	Protection class	Weight [kg]	Protection class
internally ventilated commutator motor	ball-bearing	2-steps	-20 to +40	-20 to +60	250	IP24	1,5	II

Nominal voltage [V]	Power frequency [Hz]	Rated power [W]	Type of plug according to norm:	Cable length [m]
240	50	230	Europe: CEE 7 /XVII	5
230	50-60	230	Europe: CEE 7 /XVII Switzerland: Typ 11	5
120	60	230	North America: NEMA 1-15P	5
110	50-60	230	Europe: CEE 7 /XVII	5
100	50-60	230	Japan: JISC 8308, 8358 7A	5

Pumpe F 310/F 314

Type	F 310 PP- 25/19	F 310 PP- 32/25	F 314 PP-25/19	F 314 PP-32/25	F 314 PVDF-25/19	F 314 S-28/25
Outer tube material	polypropylene				polyvinylidene fluoride	stainless steel
Type of seal	with mechanical seal			sealless		
Immersion length [mm]	300/500/ 700/1.000		500/700/1.000			
Outer Ø [mm]	25	32	25	32	25	28
Connection thread	G 1 A					G ¾ A
Materials in contact with the medium	PP, ETFE, Oxidkeramik/ PTFE/carbon, FKM, Hastelloy C		PP, ETFE, PTFE/ carbon, Hastelloy C		PVDF, ETFE, PTFE/ carbon, Hastelloy C	S (316 Ti), ETFE, PTFE/ carbon
Viscosity max. [mPas]	250					
Temperature of medium max. [°C]	45				60	
Weight including motor [kg] at a length of 300/500/700/1.000 mm	1,6/1,8/2,0/2,1	- /1,8/2,0/2,1	- /1,8/2,0/2,1	- /1,8/2,0/2,1	- /2,0/2,2/2,4	- /2,8/3,0/3,2

Performance data

JUNIORFLUX

Performance data

Speed	Delivery rate Q max. [l/min]* at:		Delivery head H max. [mwc]** at:	
	step 1	step 2	step 1	step 2
F 310 PP-25/19	17	27	2,2	5
F 310 PP-32/25	30	48	3	6,9
F 314 PP-25/19 F 314 PVDF-25/19	27	40	2,8	5,3
F 314 PP-32/25 F 314 S-28/25	44	56	4,7	8,5

Performance charts*

JUNIORFLUX

F 310 **PP-25/19**

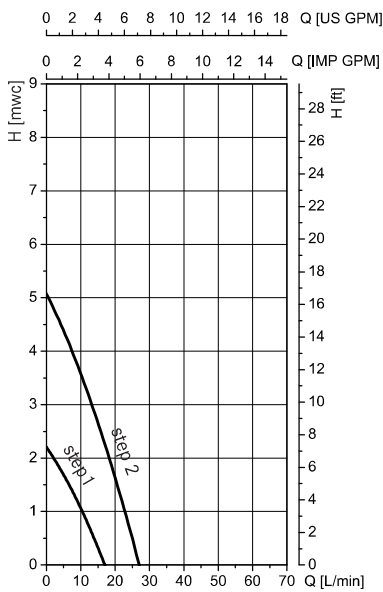

F 310 **PP-32/25**

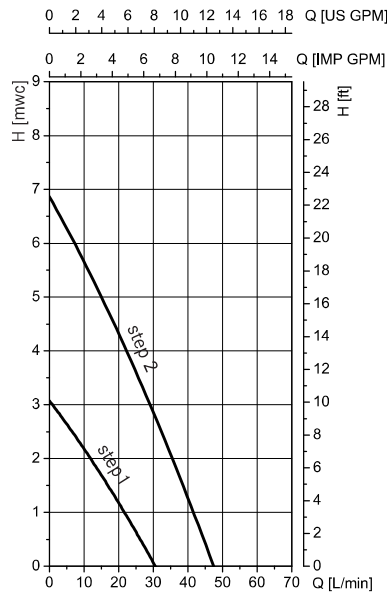

F 314 **PP-25/19**

F 314 **PVDF-25/19**

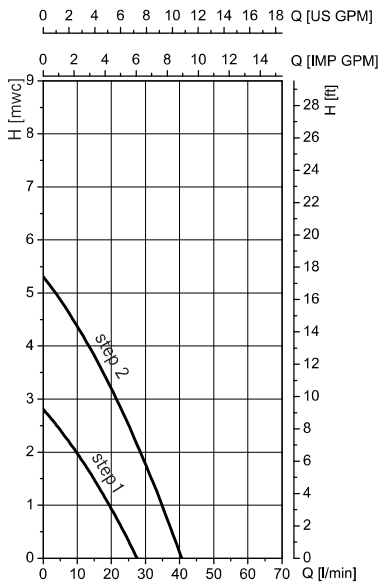

F 314 **PP-32/25**

F 314 **S-28/25**

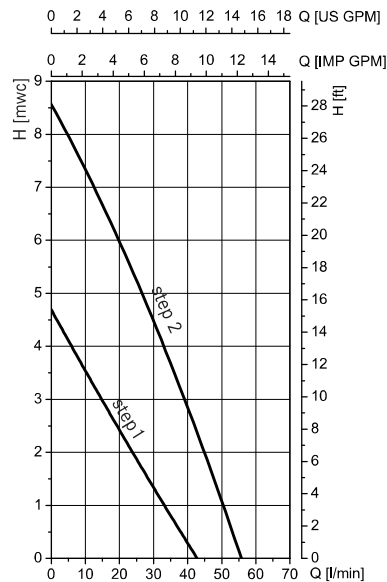

* measured with free outlet, water at 20 °C, values ± 10 %

** measured with water at 20 °C

Dimensions

JUNIORFLUX

Dimensions [mm]

JUNIORFLUX F 310 PP

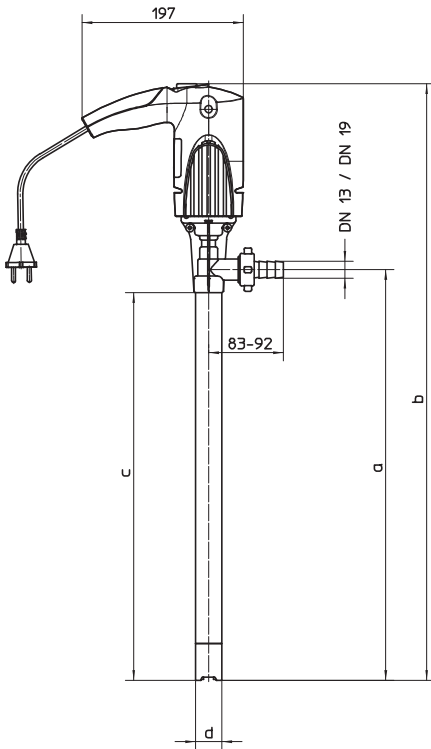

JUNIORFLUX F 314 PP/PVDF

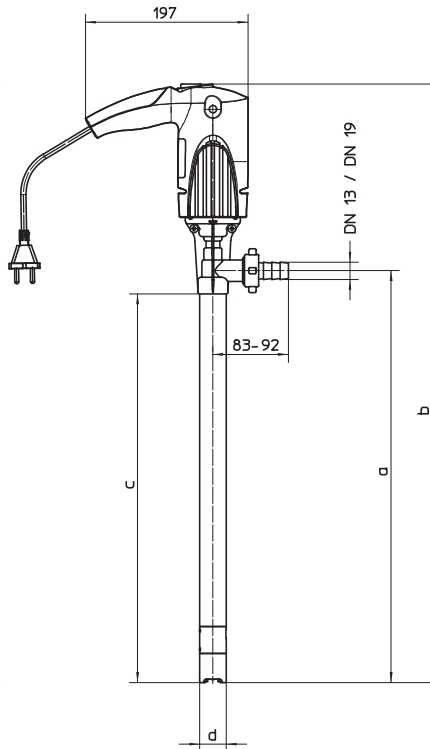

JUNIORFLUX F 314 S

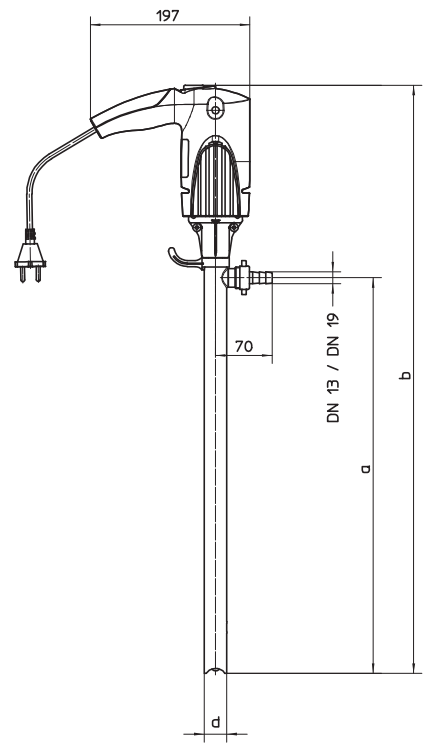

Immersion length	a	b	c	d	
1.000	1.002	1.229	974	Ø 25	Ø 32
700	702	929	674		
500	502	729	474		

Dimensions in mm

Immersion length	a	b	c	d	
1.000	1.000	1.227	972	Ø 25	Ø 32*
700	700	927	672		
500	500	727	472		

Dimensions in mm

* Version Ø 32 mm available in PP

Immersion length	a	b	c	d
1.000	989	1192	-	Ø 28
700	689	892	-	
500	489	692	-	

Dimensions in mm

Pump kit	F 310 PP-32/25	F 314 PP-25/19	F 314 PP-32/25	F 314 PP/S-32/25 AdBlue® version
Motor	F 310, 230 V, 50-60 Hz, 230 W			
Cable length [m]	5			
Type o plug according to norm:	Europe: CEE 7 /XVII			
Outer tube material	polypropylene (PP)			
Seal type	with mechanical seal	sealless		
Shaft material	Hastelloy C			Stainless steel
Immersion length [mm]	1.000	700/1.000	1.000	1.000
Outer Ø [mm]	32	25	32	32
Hose connector	DN 19	DN 13	DN 19	DN 19
Hose material	PVC			
Hose length [m]	1,5			2
Hose Ø	DN 19	DN 13	DN 19	DN 19
Material hand nozzle/seal	PP/FKM			
Connection hand nozzle	DN 19	DN 13	DN 19	DN 19
Hand nozzle outlet Ø [mm]	22			19
Weight [kg]	2,4			



JUNIORFLUX pump kit F 314 PP-25/19



JUNIORFLUX pump kit AdBlue® *

* AdBlue® is a registered trademark of:
Verband der Automobilindustrie e. V. (VDA)

Part numbers

JUNIORFLUX pump with fixed commutator motor F 310

Pump		Motor					
Pump type	Immersion length (mm)	240 V, 50 Hz	230 V, 50-60 Hz	230 V, 50-60 Hz (Swiss version)	120 V, 60 Hz	110 V, 50-60 Hz	100 V, 50-60 Hz
F 310 PP-25/19	300	10-310 41 403	10-310 41 003	on request	10-310 41 103	10-310 41 203	10-310 41 303
	500	10-310 41 405	10-310 41 005	10-310 41 505	10-310 41 105	10-310 41 205	10-310 41 305
	700	10-310 41 407	10-310 41 007	10-310 41 507	10-310 41 107	10-310 41 207	10-310 41 307
	1.000	10-310 41 410	10-310 41 010	10-310 41 510	10-310 41 110	10-310 41 210	10-310 41 310
F 310 PP-32/25	500	10-310 42 405	10-310 42 005	on request	10-310 42 105	10-310 42 205	on request
	700	10-310 42 407	10-310 42 007	10-310 42 507	10-310 42 107	10-310 42 207	
	1.000	10-310 42 410	10-310 42 010	10-310 42 510	10-310 42 110	10-310 42 210	
F 314 PP-25/19	500	10-314 41 405	10-314 41 005	10-314 41 505	10-314 41 105	10-314 41 205	10-314 41 305
	700	10-314 41 407	10-314 41 007	10-314 41 507	10-314 41 107	10-314 41 207	10-314 41 307
	1.000	10-314 41 410	10-314 41 010	10-314 41 510	10-314 41 110	10-314 41 210	10-314 41 310
F 314 PP-32/25	500	10-314 42 405	10-314 42 005	10-314 42 505	10-314 42 105	10-314 42 205	on request
	700	10-314 42 407	10-314 42 007	10-314 42 507	10-314 42 107	10-314 42 207	
	1.000	10-314 42 410	10-314 42 010	10-314 42 510	10-314 42 110	10-314 42 210	
F 314 PVDF-25/19	500	10-314 61 405	10-314 61 005	10-314 61 505	on request	10-314 61 205	10-314 61 305
	700	10-314 61 407	10-314 61 007	10-314 61 507		10-314 61 207	10-314 61 307
	1.000	10-314 61 410	10-314 61 010	10-314 61 510		10-314 61 210	10-314 61 310
F 314 S-28/25	500	10-314 21 405	10-314 21 005	on request	10-314 21 105	10-314 21 205	10-314 21 305
	700	10-314 21 407	10-314 21 007	10-314 21 507	10-314 21 107	10-314 21 207	10-314 21 307
	1.000	10-314 21 310	10-314 21 010	10-314 21 510	10-314 21 110	10-314 21 210	10-314 21 310

JUNIORFLUX pump kits with motor 230 V, 50-60 Hz, 230 W

Pump type	Immersion length	Outer Ø	Part no.
F 310	1.000	32 mm	10-310 43 010
F 314	700	25 mm	10-314 43 007
F 314	1.000	25 mm	10-314 43 010
F 314	1.000	32 mm	10-314 44 010
F 314 AdBlue®*	1.000	32 mm	10-314 44 ZV2

* AdBlue® is a registered trademark of: Verband der Automobilindustrie e. V. (VDA)

Hose connections consisting of hose connector and union nut for JUNIORFLUX F 310/F 314

Material	Nominal Ø	Part no.
PP	DN 13/DN 19	10-959 04 135
PVDF	DN 13	10-959 04 071
PVDF	DN 19	10-959 04 072
S	DN 13	10-959 04 133
S	DN 19	10-959 04 147

Other accessories:

We offer the appropriate accessories for the JUNIORFLUX, such as: hand nozzles, hoses, compression glands or liquid meters. See our brochure for accessories and the price list for the precise specifications.