



POMPE SUPER LARIO – *SUPER LARIO PUMPS*

POMPE A MANO SEMI ROTATIVE *SEMI ROTARY HAND PUMP*

Serie G

G series

Modelli da 1” - 1”1/4 - 1” 1/2 - 2”

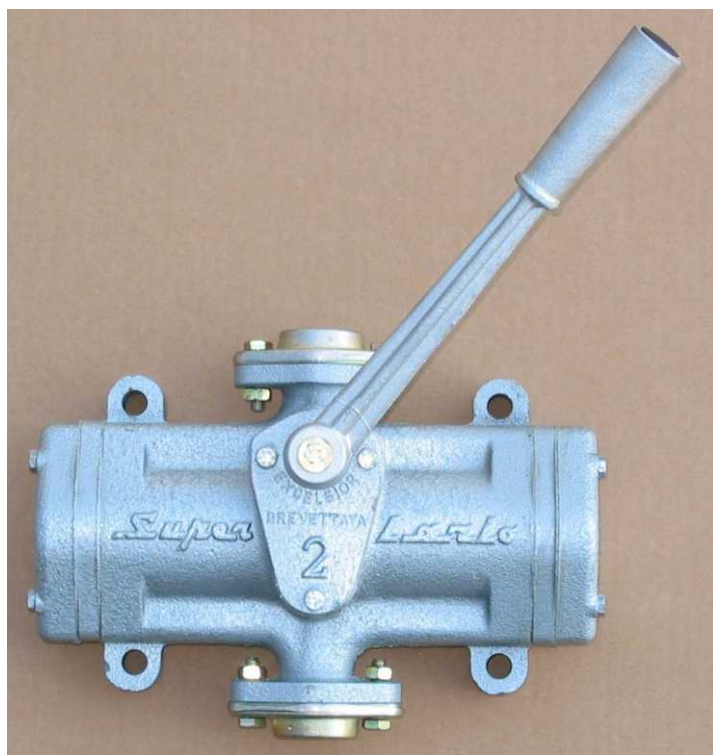

Pompe a mano a pistone, auto-adescenti, a duplice effetto, a movimento alternativo e flangiate.

Il corpo e gli interni sono in ghisa, le tenute in gomma nitrilica e la leva in lega leggera. Adatte al travaso di acqua, gasolio e olio.

Semi-rotary piston hand pumps, self-priming, double acting, reciprocating action and flanged.

Cast iron body, cover and internal parts, seals made of NBR and cast alloy handle. Suitable for water, oil and diesel.

Serie G – be

G – be series

Pompe a mano a pistone, auto-adescenti, a duplice effetto, a movimento alternativo e flangiate.

Il corpo e gli interni sono in ghisa, le tenute in FPM e la leva in lega leggera. Adatta al travaso di acqua, gasolio, olio, solventi e benzine.

Semi-rotary piston hand pumps, self-priming, double acting, reciprocating action and flanged.

Cast iron body, cover and internal parts, seals made of FPM and cast alloy handle. Suitable for water, diesel, oil, solvents and fuels.



POMPE SUPER LARIO – *SUPER LARIO PUMPS*

POMPE A MANO SEMI ROTATIVE *SEMI ROTARY HAND PUMP*

Serie B AM

B AM series

Modelli da 1" - 1"1/4 - 1" 1/2 - 2"

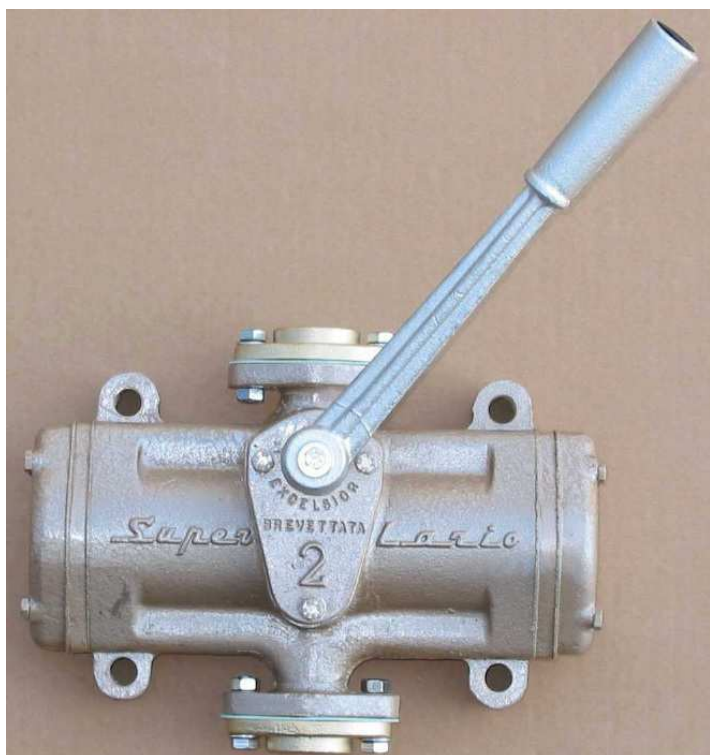

Pompe a mano a pistone, auto-adescenti, a duplice effetto, a movimento alternativo e flangiate.

Il corpo e gli interni sono in bronzo, le tenute in gomma nitrilica e la leva in lega leggera. Adatte al travaso di acqua di mare e acqua dolce.

Semi-rotary piston hand pumps, self-priming, double acting, reciprocating action and flanged.

Bronze body, cover and internal parts, seals made of NBR and cast alloy handle. Suitable for water and sea water.

Serie B – be

B – be series

Pompe a mano a pistone, auto-adescenti, a duplice effetto, a movimento alternativo e flangiate.

Il corpo e gli interni sono in bronzo, le tenute in Viton® e la leva in lega leggera. Adatte al travaso di acqua, solventi e benzine.

Semi-rotary piston hand pumps, self-priming, double acting, reciprocating action and flanged.

Bronze body, cover and internal parts, seals made of Viton® and cast alloy handle. Suitable for water, solvents and fuels.



POMPE SUPER LARIO – SUPER LARIO PUMPS

Dimensioni

Dimensions

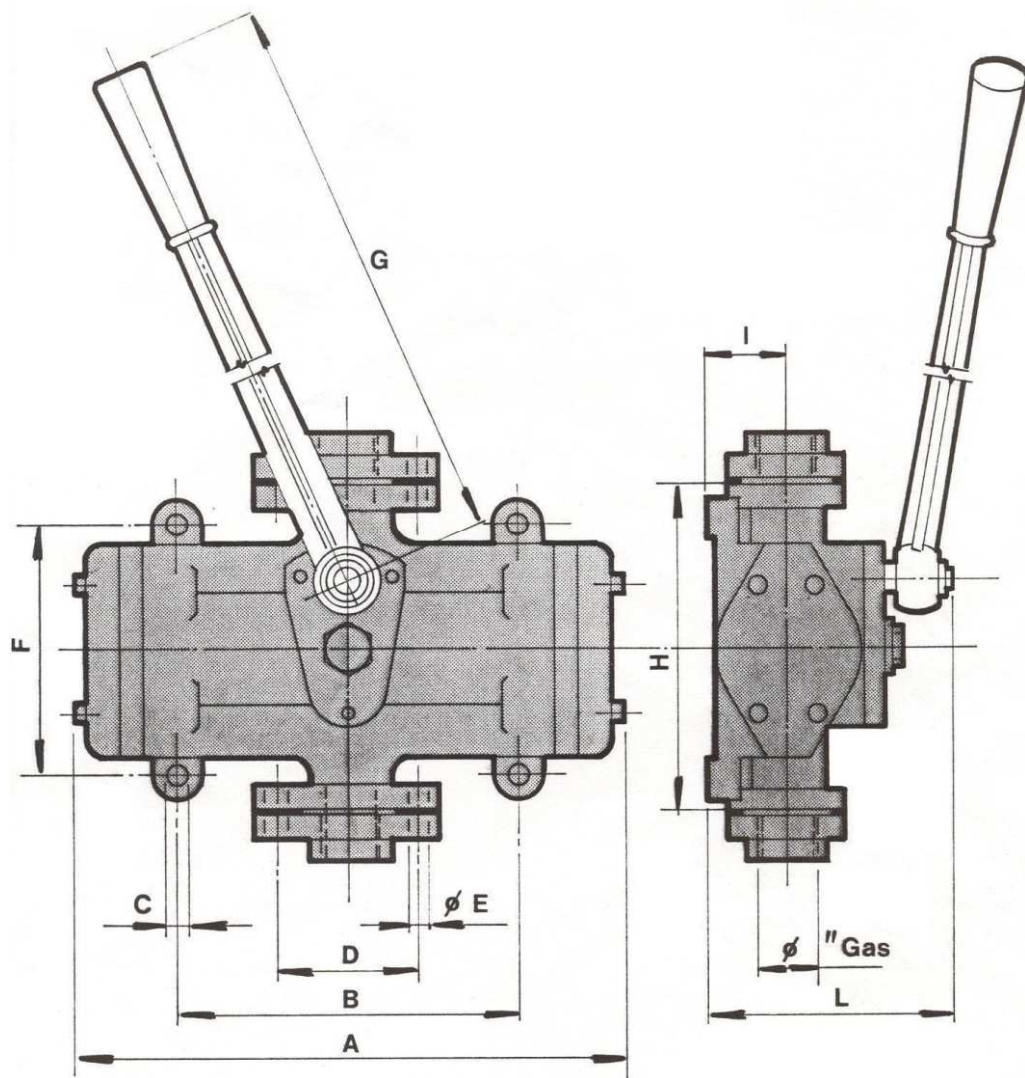

	GHISA - CAST IRON G / G-be BRONZO - BRONZE B / B-be			
TIPO - TYPE	SL 2	SL3	SL 4	SL 5
DIAMETRO - DIAMETER	1"	1" 1/4	1" 1/2	2"
PESO - WEIGHT (kg)	8,7	12,2	18,5	28,1
A	280	330	370	480
B	185	210	250	340
C	11	13	13	13
D	64	74	85	85
E	9	9	9	9
F	132	165	190	220
G	270	330	500	500
H	170	200	250	260
I	39	45	50	65
L	130	165	190	220



POMPE SUPER LARIO – *SUPER LARIO PUMPS*

POMPE A MANO SEMI ROTATIVE *SEMI ROTARY HAND PUMP*

Caratteristiche

- SL 2 (1")
Mandata: 25 m
Aspirazione: 8 m
Portata: 40 lt/min
- SL 3 (1" 1/4)
Mandata: 25 m
Aspirazione: 8 m
Portata: 55 lt/min
- SL 4 (1" 1/4)
Mandata: 25 m
Aspirazione: 8 m
Portata: 80 lt/min
- SL 5 (2")
Mandata: 25 m
Aspirazione: 8 m
Portata: 110 lt/min

Dimensions

- SL 2 (1")
Delivery head: 25 m
Suction head: 8 m
Flow rate: 40LPM
- SL 3 (1" 1/4)
Delivery head: 25 m
Suction head: 8 m
Flow rate: 55 LPM
- SL 4 (1" 1/4)
Delivery head: 25 m
Suction head: 8 m
Flow rate: 80 LPM
- SL 5 (2")
Delivery head: 25 m
Suction head: 8 m
Flow rate: 110 LPM



POMPE SUPER LARIO – *SUPER LARIO PUMPS*

L'OFFICINA MECCANICA BINDA declina ogni responsabilità per usi diversi da quelli previsti senza il proprio benessere. Le portate e le pressioni relative sono indicative e corrispondono ai valori massimi ottenibili in condizioni standard di utilizzo a temperatura ambiente. Per il travaso di benzine si consiglia l'utilizzo di prodotti con tenute in Viton.

Le immagini contenute in questo depliant sono puramente indicative, pertanto l'OFFICINA MECCANICA BINDA si riserva il diritto di apportare modifiche migliorative dei prodotti senza nessun obbligo di preavviso. L'OFFICINA MECCANICA BINDA si riserva il diritto di cambiare i prezzi senza preavviso.

I prodotti forniti dall'OFFICINA MECCANICA BINDA sono garantiti 12 mesi dall'acquisto. Tutte le pompe sono *MADE IN ITALY*, marchiate CE, fornite di istruzioni d'uso e garantite a norme di Legge.

OFFICINA MECCANICA BINDA declines to assume any responsibility if the pump is used for different applications without prior writing consent.

Capacities and pressures are approximated and refer to the maximum obtainable values for pumps used in standard conditions and at room temperature. To transfer fuel we suggest to use products with Viton seals.

The images shown in this depliant are indicative, OFFICINA MECCANICA BINDA reserves the right to make products improvement without prior notice.

OFFICINA MECCANICA BINDA reserve the right to change prices without notice.

Products supplied by OFFICINA MECCANICA BINDA are guaranteed for 12 months from purchase. All pumps are MADE IN ITALY, CE marked, included instructions for use and guaranteed by law.